

Collaborative Parallel Grippers

ECG2-25140 2-Finger

ECG is a collaborative 2-finger parallel gripper that is equipped with symmetrically parallel fingers.

Advantages

- Compact design
- Smooth body with rounded edges ideal for collaborative applications
- Grip control: force and position adjustment
- Quick open/close time with speed adjustment
- Grip feedback and part detection: gripper status can be read at the PLC/Controller and visualized on the unit via LED's
- Plug and play: mechanical and software interface for major cobot manufacturers
- Multiple communication modes: the gripper supports Modbus RTU protocol and IO mode control. Other protocols such as USB and ETHERNET can be implemented through a protocol converter.
- ROS compatible
- Designed for harsh environments
- Grip actuation via embedded controller.
- Brake locking mechanism.



SPECIFICATIONS

Model	Stroke per Jaw	Gripping Force per Jaw	Total Gripping Force	Opening/Closing Time	Nominal Voltage	Nominal Current	Max Current	Repeatability (Positioning)	Recommended Workpiece Weight*	Weight
ECG2-25140	25 mm 0.98 in	40 - 140 N 8.99 - 31.47 lb	80 - 280 N 17.98 - 62.95 lb	0.6 / 0.6 s	24 V DC \pm 10%	0.40 A	1.00 A	\pm 0.03 mm \pm 0.001 in	3.0 kg 6.61 lb	1.00 kg 2.20 lb

* Recommended workpiece weight depends on the shape of the part, the material and friction of the contact surface and the acceleration of the motion.

Communication Interface **Standard: Modbus RTU (RS485), Digital I/O**
Optional: TCP/IP, USB2.0, CAN2.0A, PROFINET, EtherCAT

IP Protection Class **IP 67**

Noise Emission (Sound Pressure) \leq **40 dB(A) in any direction**

Recommended operating environment **0-40 °C (32-104 °F), < 85% RH**

For this type of gripper the use of the standard fingers is recommended.

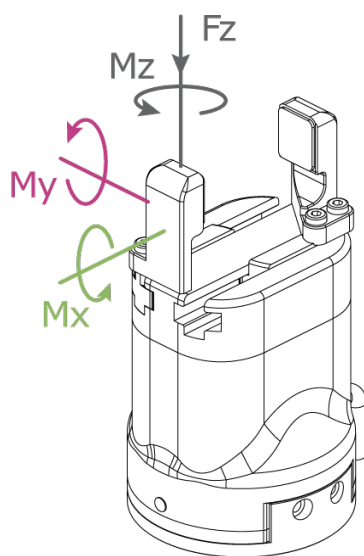

Allowable vertical load (static)

Fz 300 N (67.44 lb)

Allowable moment (static)

Mx 7 Nm (61.96 in-lb)

My 7 Nm (61.96 in-lb)

Mz 7 Nm (61.96 in-lb)



PRODUCT INFORMATION

ECG2-25140 2-Finger

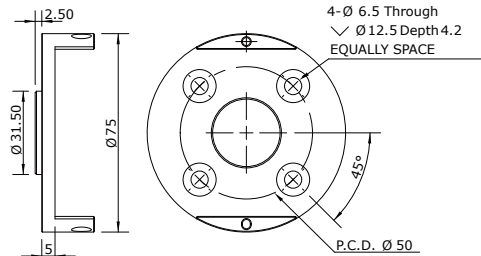
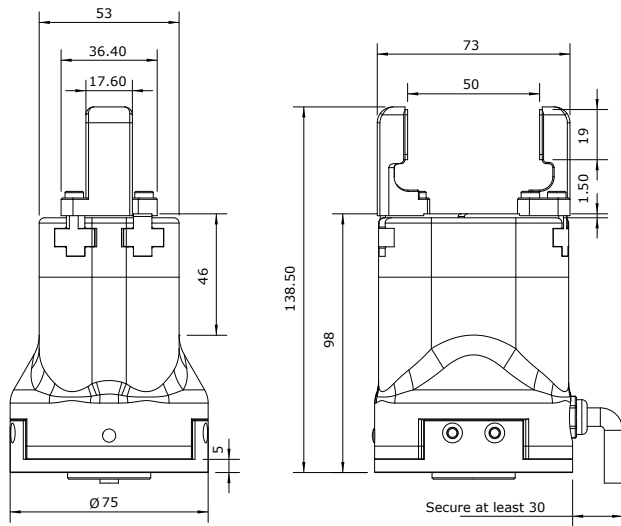

Conform to ISO 9409-1-50-4-M6 Standard flange

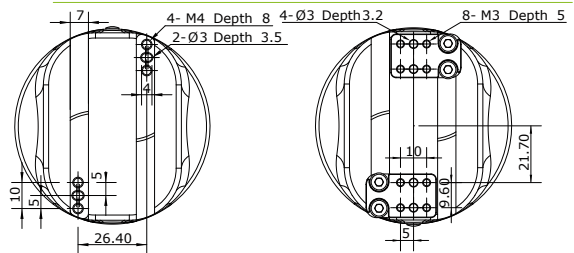

Rail mounting holes

Custom finger mounting size

Applied Robotics™
 A COMPANY OF **EFFECTO®**
 Applied Robotics Inc.
 648 Saratoga Road
 Glenville, NY 12302 USA
 Tel. +1 518 384 1000 Fax +1.5183841200
 info@appliedrobotics.com
 www.appliedrobotics.com

EFFECTO GROUP
 EFFECTO GROUP S.p.A.
 Via Roma, 141/143
 28017 San Maurizio d'Opaglio (NO) - Italy
 Tel. +39 0322 96142 Fax +39 0322 967453
 info@effectogroup.com
 www.effecto.com

