

# Electric Grippers SG 050 2-Finger

SG is a 2-finger electric gripper with serial interface that optimizes the sensitive handling of the various products and devices in the laboratory automation as well as a wide range of applications in the general industry.

## Advantages

- Precise positioning of the gripper fingers
- Programmable gripping force and speed
- High positioning speed
- Simple integration in laboratory and process automation
- Grip actuation via embedded controller
- Easy cleaning
- IP30 protection class (IP68 optional)
- Additional accessories: connection cable, mounting interfaces, gripping fingers

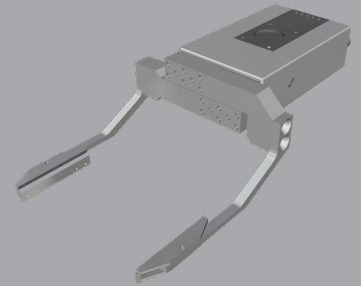

## SPECIFICATIONS

Model	Stroke per Jaw	Min. Cycle Time	Gripping Force per Jaw	Total Gripping Force	Speed	Recommended Workpiece Weight*	Position Accuracy	Repeatability	Weight
<b>SG 050</b>	25 mm 0.98 in	140 ms	50 N 11.24 lb	100 N 22.48 lb	175 mm/s	0.5 kg 6.61 lb	± 0.05 mm ± 0.002 in	± 0.01 mm ± 0.0004 in	0.39 kg 0.86 lb

\* Recommended workpiece weight depends on the shape of the part, the material and friction of the contact surface and the acceleration of the motion.

Communication Interface **RX/TX (RS232/ RS485)**

Nominal Voltage **24 V DC**

Maximum Power Consumption **0.5 Amp**

Noise Emission (Sound Pressure) **≤ 40 dB(A) in any direction**

Recommended operating environment **-20 - +60°C (-4 - +104 °F)**

Example of configuration:



BASIC GRIPPER		
<b>STEP 1</b>	SG 050	
INTERFACE		
<b>STEP 2</b>	R [1/2]	[1] RS 232 [2] RS 485
PICK & PLACE FUNCTION		
<b>STEP 3</b>	P	SG 050 Pick & Place (25N)
IP68 AND H <sup>2</sup> O <sup>2</sup> PROTECTION		
<b>STEP 4</b>	W H	IP68 waterproof IP68 waterproof and H <sup>2</sup> O <sup>2</sup> resistant
SAFETYGRIP - MAGNETIC BRAKE		
<b>STEP 5</b>	S [1/2]	[1] SG with mounting from above [2] SG with mounting from behind
CLEAN ROOM ISO 14644		
<b>STEP 6</b>	C [1/3]	[1] Clean room class ISO 6 [2] Clean room class ISO 5 [3] Clean room class ISO 1

### Interface RS232 or RS485

- 24 volts
- 50 mm gripping stroke
- 50 N closing force

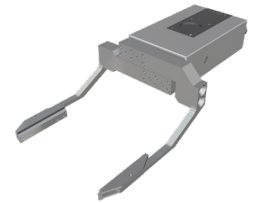

### Safetygrip - Magnetic brake

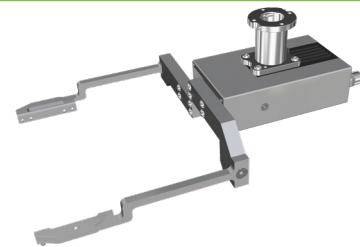

# PRODUCT INFORMATION

# SG 2-Finger

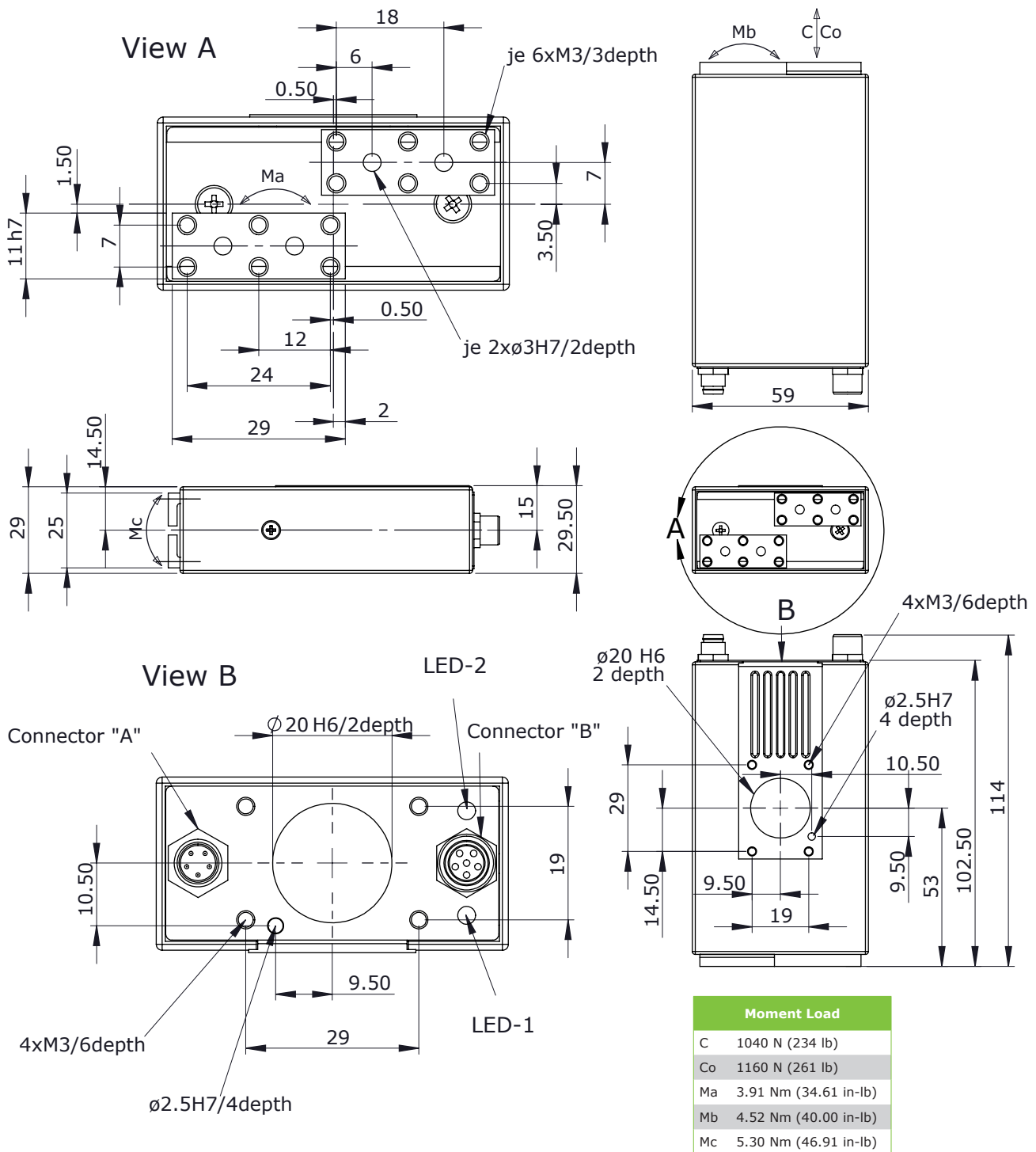

Applied Robotics  
 648 Saratoga Road  
 Glensville, NY 12302 USA  
 Tel. +1 518 384 1000 Fax +1.5183841200  
 info@appliedrobotics.com  
 www.appliedrobotics.com



EFFECTO GROUP S.p.A.  
 Via Roma, 141/143  
 28017 San Maurizio d'Opaglio (NO) - Italy  
 Tel. +39 0322 96142 Fax +39 0322 967453  
 info@effecto.com  
 www.effecto.com

