

Pinze pneumatiche mono-dito angolari per staffaggio, serie OF

- Azionamento a semplice effetto.
- Sensori magnetici opzionali.
- Grasso alimentare FDA-H1.

One finger angular pneumatic grippers for clamping, series OF

- Single acting.
- Optional magnetic sensors.
- Food grade grease FDA-H1.

	OFA14-35	OFA20-35 OFA20-35S	OFA30-35 OFA30-35S
Fluido Medium	Aria compressa a norma ISO 8573-1:2010 [7:4:4] Compressed air in compliance with ISO 8573-1:2010 [7:4:4]		
Corpo pinza Gripper body	Alluminio Aluminium		
Pressione di esercizio Pressure range	2.5 ÷ 8 bar		
Temperatura di esercizio Temperature range	5 ÷ 60 °C.		
Corsa Stroke	35°		
Alesaggio Piston bore	Ø10 mm	Ø16 mm	Ø25 mm
Coppia di chiusura a 6 bar Closing torque at 6 bar	26 Ncm	100 Ncm	430 Ncm
Consumo d'aria per ciclo Cycle air consumption	0.4 cm ³	1.24 cm ³	4.56 cm ³
Peso Weight	25 g	65 g 86 g	206 g 272 g

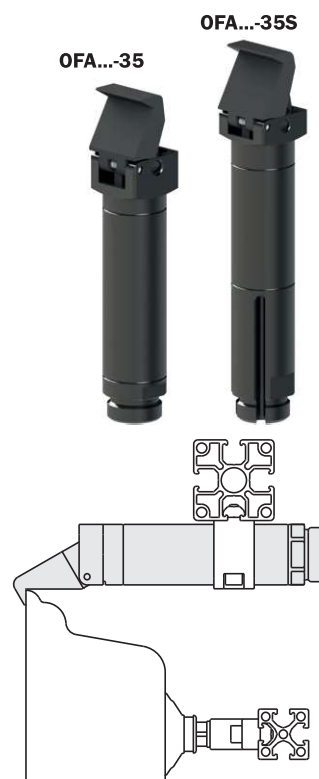

	OFS14-90	OFS20-90 OFS20-90S	OFS30-90 OFS30-90S
Fluido Medium	Aria compressa a norma ISO 8573-1:2010 [7:4:4] Compressed air in compliance with ISO 8573-1:2010 [7:4:4]		
Corpo pinza Gripper body	Alluminio Aluminium		
Pressione di esercizio Pressure range	2.5 ÷ 8 bar		
Temperatura di esercizio Temperature range	5 ÷ 60 °C.		
Corsa Stroke	95°		
Alesaggio Piston bore	Ø10 mm	Ø16 mm	Ø25 mm
Coppia di chiusura a 6 bar Closing torque at 6 bar	19 Ncm	70 Ncm	300 Ncm
Consumo d'aria per ciclo Cycle air consumption	1 cm ³	3.52 cm ³	12.9 cm ³
Peso Weight	23 g	60 g 80 g	185 g 245 g

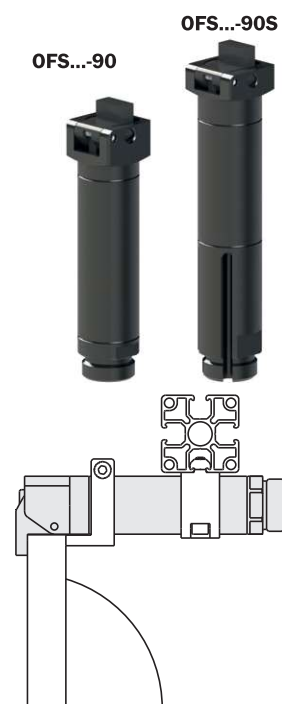

Pinze pneumatiche mono-dito angolari per staffaggio, serie OF

- Azionamento a semplice effetto.
- Sensori magnetici opzionali.
- Grasso alimentare FDA-H1.

One finger angular pneumatic grippers for clamping, series OF

- Single acting.
- Optional magnetic sensors.
- Food grade grease FDA-H1.

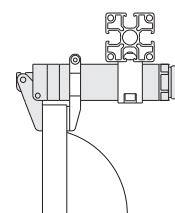

	OFR14-95	OFR20-95 OFR20-95S	OFR30-95 OFR30-95S
Fluido Medium	Aria compressa a norma ISO 8573-1:2010 [7:4:4] Compressed air in compliance with ISO 8573-1:2010 [7:4:4]		
Corpo pinza Gripper body	Alluminio Aluminium		
Pressione di esercizio Pressure range	2.5 ÷ 8 bar		
Temperatura di esercizio Temperature range	5 ÷ 60 °C.		
Corsa Stroke	95°		
Alesaggio Piston bore	Ø10 mm	Ø16 mm	Ø25 mm
Coppia di chiusura a 6 bar Closing torque at 6 bar	19 Ncm	70 Ncm	300 Ncm
Consumo d'aria per ciclo Cycle air consumption	1 cm ³	3.52 cm ³	12.9 cm ³
Peso Weight	25 g	60 g 81 g	193 g 257 g

	OFR14-95M	OFR20-95M OFR20-95SM	OFR30-95M OFR30-95SM
Fluido Medium	Aria compressa a norma ISO 8573-1:2010 [7:4:4] Compressed air in compliance with ISO 8573-1:2010 [7:4:4]		
Corpo pinza Gripper body	Alluminio Aluminium		
Pressione di esercizio Pressure range	2.5 ÷ 8 bar		
Temperatura di esercizio Temperature range	5 ÷ 60 °C.		
Corsa Stroke	95°		
Alesaggio Piston bore	Ø10 mm	Ø16 mm	Ø25 mm
Coppia di chiusura a 6 bar Closing torque at 6 bar	19 Ncm	70 Ncm	300 Ncm
Consumo d'aria per ciclo Cycle air consumption	1 cm ³	3.52 cm ³	12.9 cm ³
Peso Weight	25 g	60 g 81 g	790 g 990 g

	OFR14-95G	OFR20-95G OFR20-95SG	OFR30-95G OFR30-95SG
Fluido Medium	Aria compressa a norma ISO 8573-1:2010 [7:4:4] Compressed air in compliance with ISO 8573-1:2010 [7:4:4]		
Corpo pinza Gripper body	Alluminio Aluminium		
Pressione di esercizio Pressure range	2.5 ÷ 8 bar		
Temperatura di esercizio Temperature range	5 ÷ 60 °C.		
Corsa Stroke	95°		
Alesaggio Piston bore	Ø10 mm	Ø16 mm	Ø25 mm
Coppia di chiusura a 6 bar Closing torque at 6 bar	19 Ncm	70 Ncm	300 Ncm
Consumo d'aria per ciclo Cycle air consumption	1 cm ³	3.52 cm ³	12.9 cm ³
Peso Weight	30 g	80 g 100 g	230 g 300 g

Unità Rotanti
Rotary UnitsCambia Utensile
Quick ChangerProfili e Staffe
Profiles and BracketsPinze
GrippersAttuatori Lineari
Linear ActuatorsSospensioni
SuspensionsTaglierini
NippersKit-Robot
Robot KitAccessori Opzionali
OptionsSensori
Sensors

Riscontro per pinze OFR

(kit completo di viti)

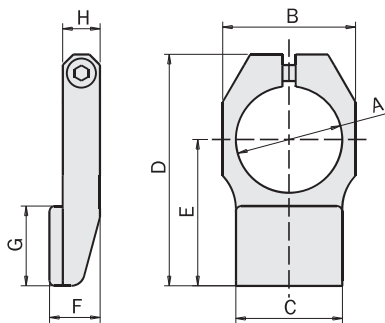

Fixed stopper for OFR grippers

(kit with screws)

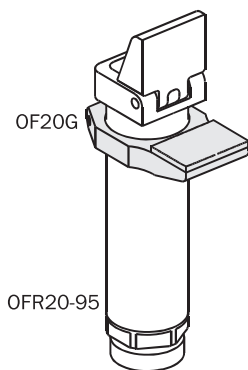

	OF14G	OF20G	OF30G
A [mm]	Ø14	Ø20	Ø30
B [mm]	19	25	37
C [mm]	14	20	30
D [mm]	32	43.5	63
E [mm]	19	27.5	40
F [mm]	10	9.5	12
G [mm]	11	15	20
H [mm]	6	7	9
Peso Weight	6g	12g	30g

Riscontro per sensore magnetico

(kit completo di viti)

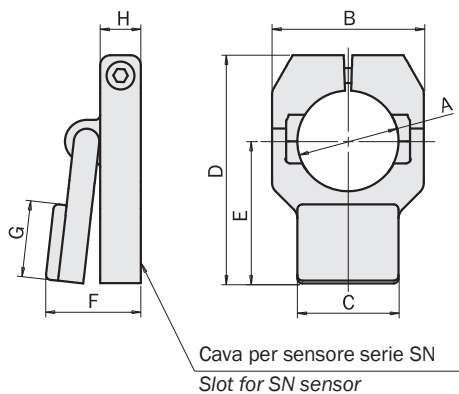

Stopper for magnetic sensor

(kit with screws)

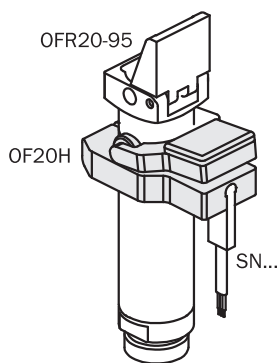

	OF14H	OF20H	OF30H
A [mm]	Ø14	Ø20	Ø30
B [mm]	22	30	42
C [mm]	14	20	30
D [mm]	34.5	45	64
E [mm]	21	28	40
F [mm]	17.6	18.7	25.5
G [mm]	11	15	20
H [mm]	8	8	12
I [mm]	Cava per sensori SN Slot for SN sensors		
Peso Weight	15g	20g	28g

Riscontro per sensore di vuoto

(kit completo di viti)

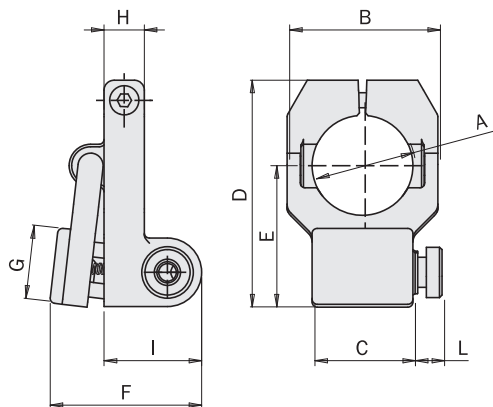

Stopper for vacuum sensor

(kit with screws)

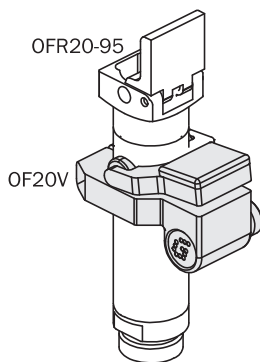

	OF14V	OF20V	OF30V
A [mm]	Ø14	Ø20	Ø30
B [mm]	22	30	42
C [mm]	14	20	30
D [mm]	34.5	45.1	64
E [mm]	21	28.1	40
F [mm]	28.9	30.1	38
G [mm]	11	15	20
H [mm]	8	8	12
I [mm]	19.3	19.5	24.4
L [mm]	11.3	5.8	5.8
Peso Weight	8.9	13.4	32.7

Sensori magnetici opzionali

Il rilevamento della posizione di lavoro è affidato a uno o più sensori magnetici di prossimità (opzionali), che rilevano la posizione attraverso il magnete sul pistone. Quindi, per un corretto funzionamento, è da evitare l'impiego in presenza di forti campi magnetici od in prossimità di grosse masse di materiale ferromagnetico.

I sensori utilizzabili sono:

SN4N225-G	PNP	Cavo 2.5m 2.5m cable
SN4M225-G	NPN	
SN3N203-G	PNP	Connettore M8 Snap M8 plug connector
SN3M203-G	NPN	
SS4N225-G	PNP	Cavo 2.5m 2.5m cable
SS4M225-G	NPN	
SS3N203-G	PNP	Connettore M8 Snap M8 plug connector
SS3M203-G	NPN	

Sono tutti dotati di un cavo piatto a tre fili e di un led.

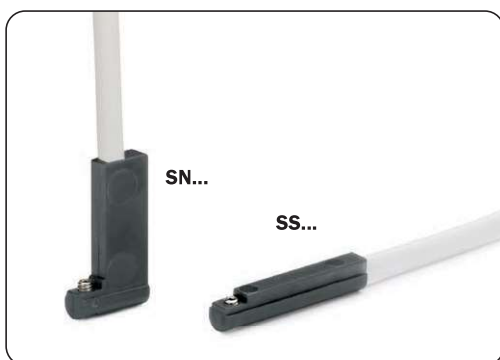

OF...	SWP-...
OF14...	SWP-014
OF20...	SWP-020
OF30...	SWP-030

Nelle versioni ...S i sensori sono annegati nelle apposite cave. Nelle altre versioni è necessaria una fascetta esterna (SWP-...).

Optional magnetic sensors

The operating position is detected by magnetic proximity sensors (optional) through a magnet placed on the piston. The use of magnetic proximity sensors is to be avoided in the vicinity of large masses of ferromagnetic material or intense magnetic fields as this may cause detection problems.

The sensors that can be used are:

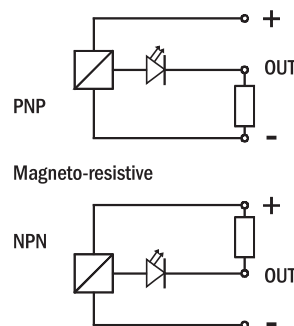

They are all provided with a 3-wire flat cable and a LED.

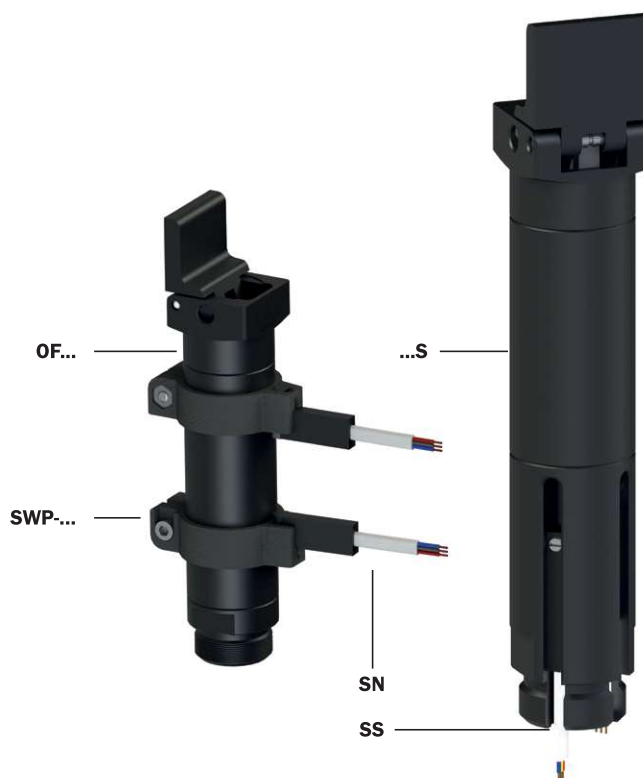

In the ...S versions, the sensors are embedded in their slots. In the other versions, an external bracket (SWP-...) is required.

Dimensioni (mm)
Dimensions (mm)

OFA...

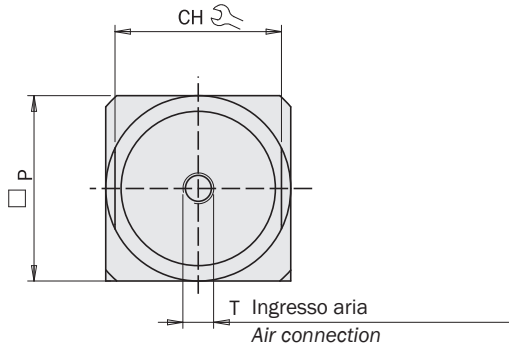

	OFA14-35	OFA20-35	OFA30-35
A	74	106	153
B	45.5	68.5	100
D	14	20.5	30
E	16	23	34
F	5.5	8	11
G	4.5	6	8
H	3.4	3.9	6
J	2	2.5	4
K	Ø14	Ø20	Ø30
L	14	20	30
M	M12x1	M17x1	M27x1
P	14	20	30
S	13.5	20.2	30.5
T	M5	M5	M5
CH	12	17	27

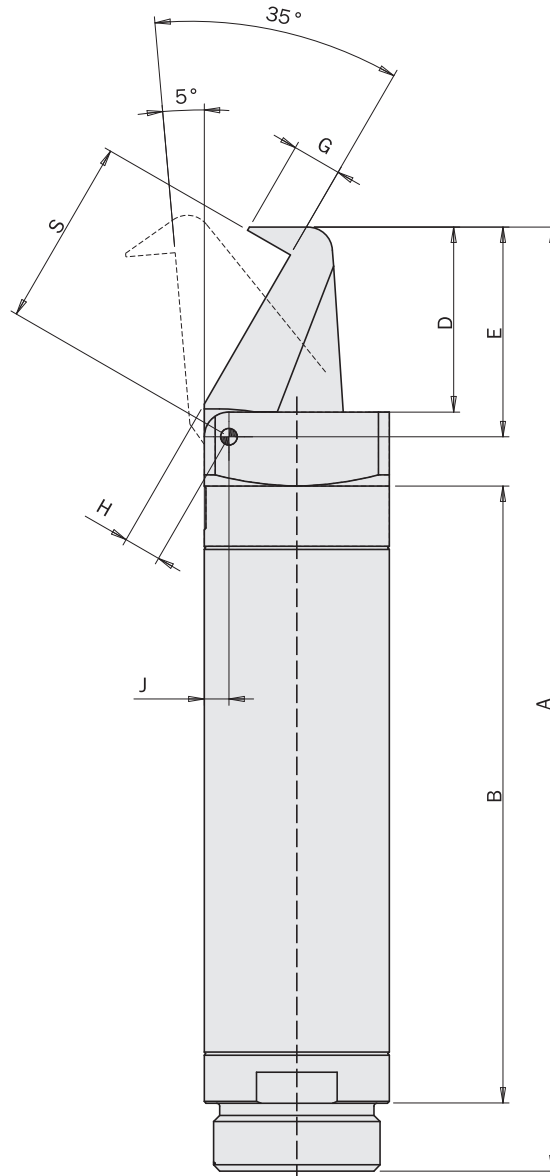
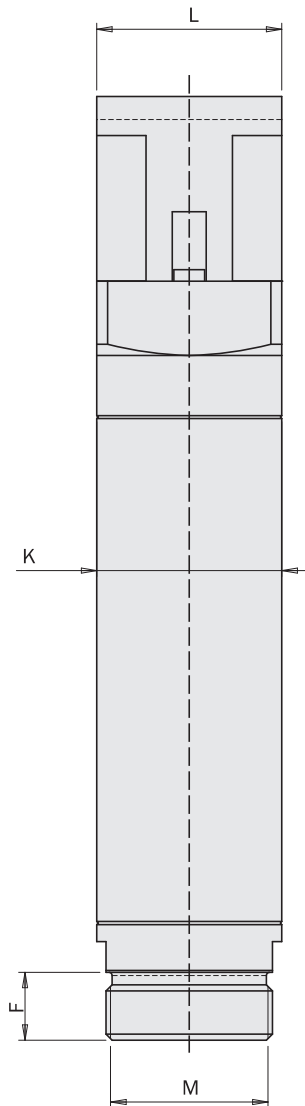

FIRST ANGLE PROJECTION

Dimensioni (mm)
Dimensions (mm)

OFA...S

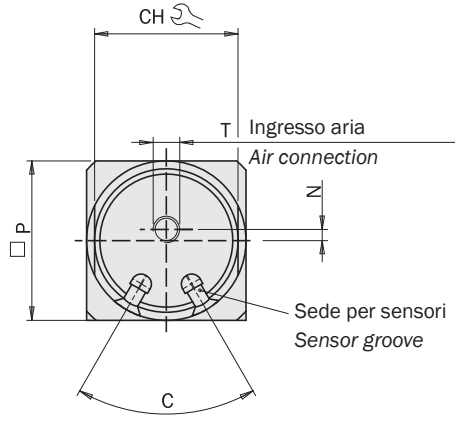

	OFA20-35S	OFA30-35S
A	120.5	178
B	83	125
C	80°	60°
D	20.5	30
E	23	34
F	8	11
G	6	8
H	3.9	6
J	2.5	4
K	Ø20	Ø30
L	20	30
M	M17x1	M27x1
N	1.5	-
P	20	30
S	20.2	30.5
T	M5	M5
CH	17	27

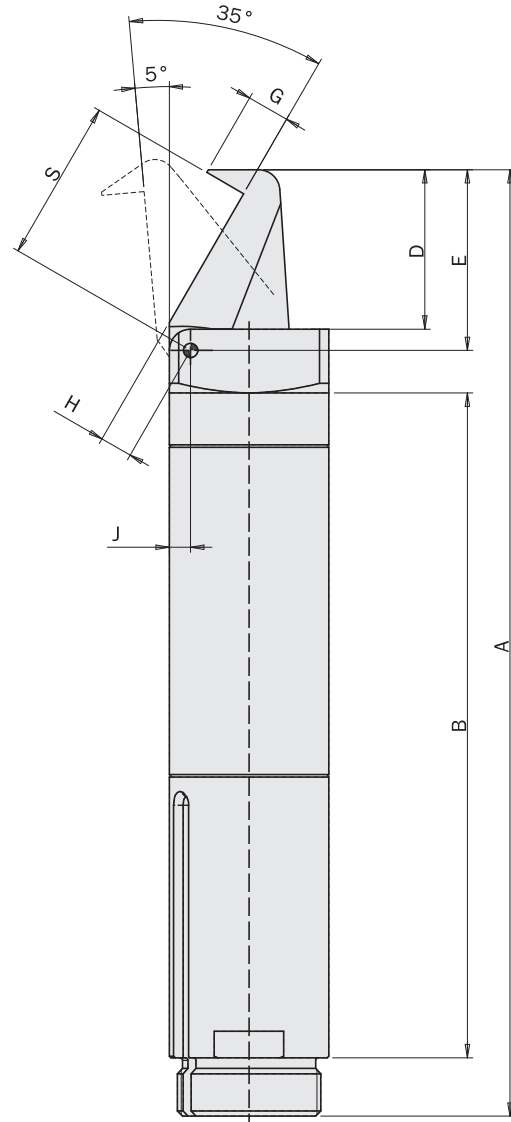
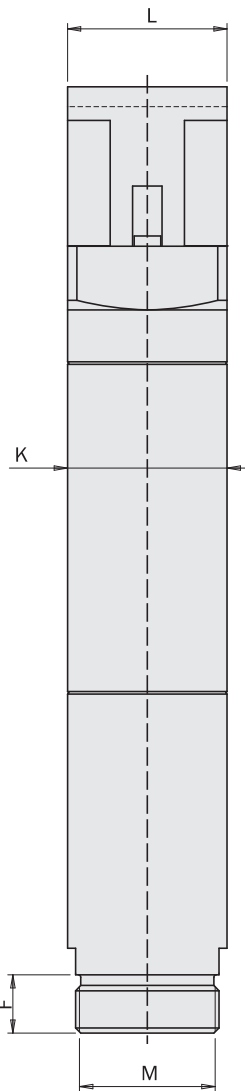

FIRST ANGLE PROJECTION

Dimensioni (mm)
Dimensions (mm)

OFR...

	A	B	D	E	F	J	K	L	M	N	O	P	Q	R	S	T	CH
OFR14-95	72	45.5	12	14	5.5	2	Ø14	14	M12x1	-	-	3	-	9.5	14	M5	12
OFR20-95	103	68.5	17.5	20	8	2.5	Ø20	20	M17x1	-	-	4	-	14.5	20	M5	17
OFR30-95	148	100	25	29	11	4	Ø30	30	M27x1	24	-	5	-	20	30	M5	27
OFR14-95M	72	45.5	12	14	5.5	2	Ø14	14	M12x1	-	2.5	3	11	9.5	14	M5	12
OFR20-95M	103	68.5	17.5	20	8	2.5	Ø20	20	M17x1	-	2.5	4	15	14.5	20	M5	17
OFR30-95M	148	100	25	29	11	4	Ø30	30	M27x1	24	3	5	20	20	30	M5	27

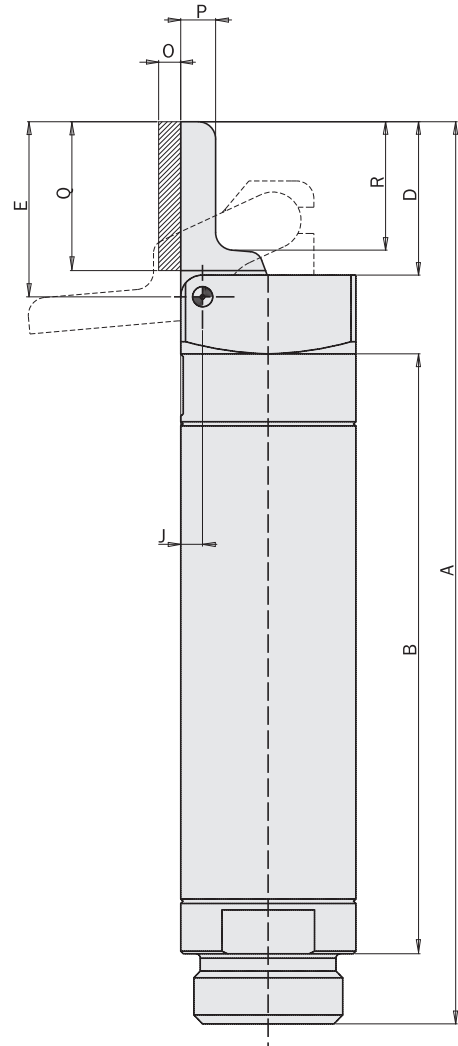
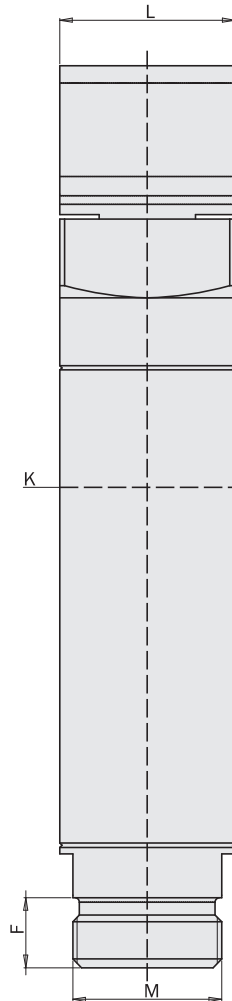
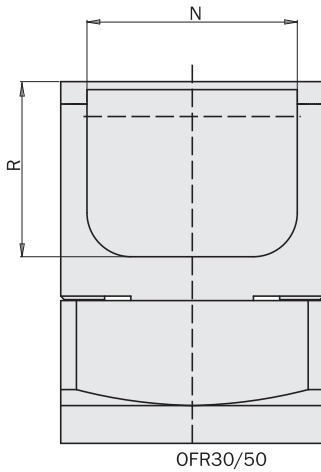
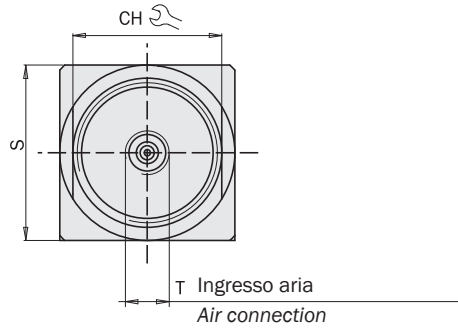

FIRST ANGLE PROJECTION

Unità Rotanti
Rotary Units

Cambia Utensile
Quick Changer

Profili e Staffe
Profiles and Brackets

Pinze
Grippers

Attuatori Lineari
Linear Actuators

Sospensioni
Suspensions

Taglierini
Nippers

Kit-Robot
Robot Kit

Accessori Opzionali
Options

Sensori
Sensors

Dimensioni (mm)
Dimensions (mm)

OFR...S

	A	B	C	D	E	F	J	K	L	M	N	O	P	Q	R	S	T	U	CH
OFR20-95S	117.5	83	80°	17.5	20	8	2.5	Ø20	20	M17x1	-	-	4	-	14.5	20	M5	1.5	17
OFR30-95S	173	125	60°	25	29	11	4	Ø30	30	M27x1	24	-	5	-	20	30	M5	-	27
OFR20-95SM	117.5	83	80°	17.5	20	8	2.5	Ø20	20	M17x1	-	2.5	4	15	14.5	20	M5	1.5	17
OFR30-95SM	173	125	60°	25	29	11	4	Ø30	30	M27x1	24	3	5	20	20	30	M5	-	27

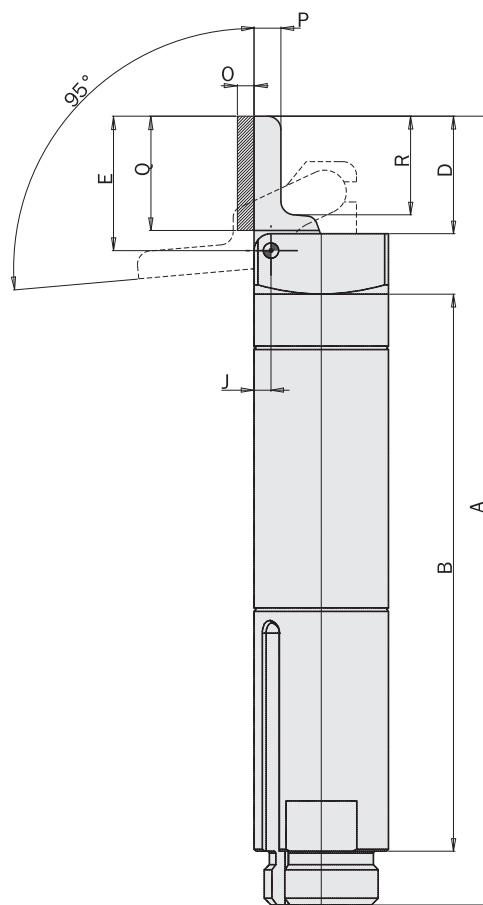
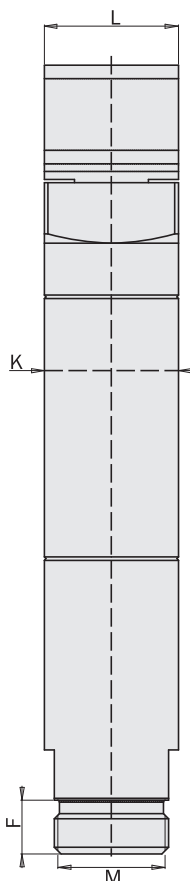
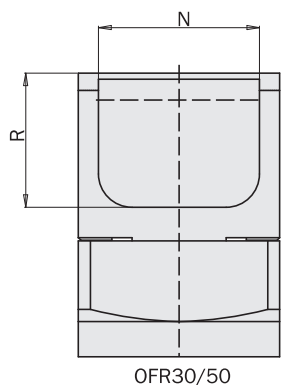
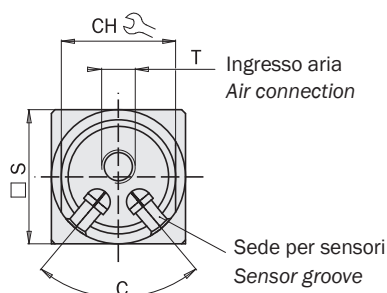

Dimensioni (mm)
Dimensions (mm)

OFS...

	A	B	C	D	E	F	G	H	J	K	L	M	N	P	CH
OFS14-90	64	45.5	54.5	Ø14	5.5	M5	2°	8	2	9	14	M12x1	4	4	12
OFS20-90	91.5	68.5	77.5	Ø20	8	M5	2°	11	2.5	13	20	M17x1	6	5	17
OFS30-90	134	100	112	Ø30	11	M5	2°	14	4	20	30	M27x1	11	6	27

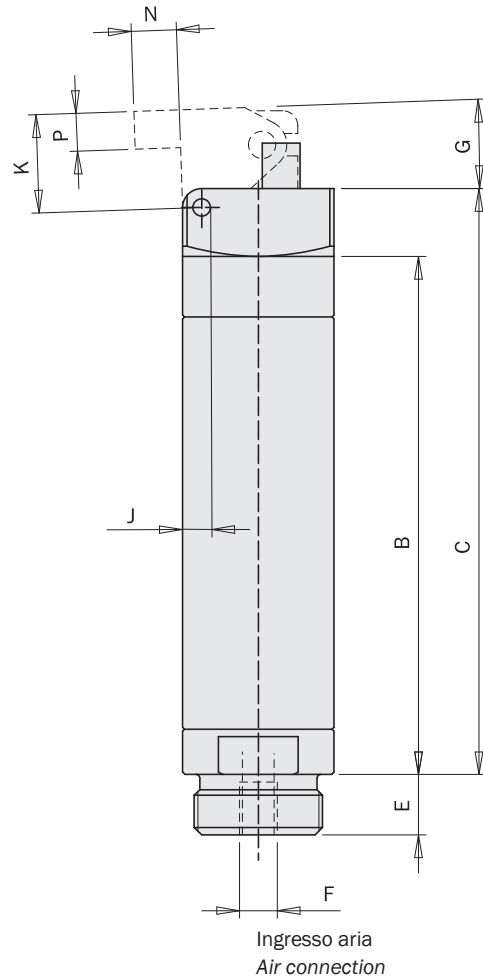
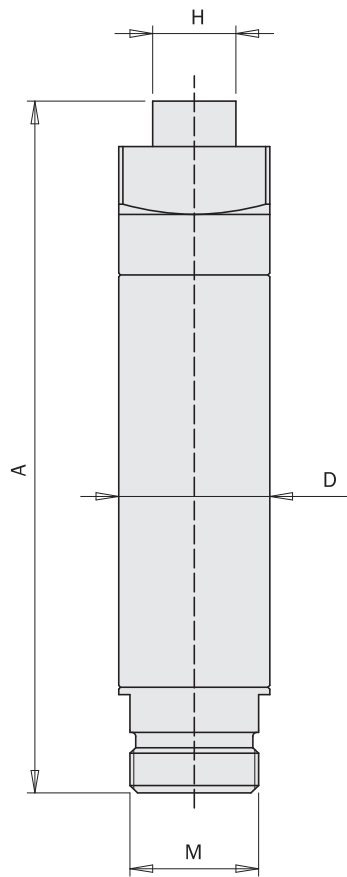
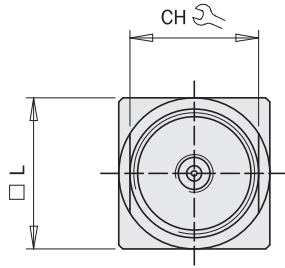

FIRST ANGLE
PROJECTION

Unità Rotanti
Rotary Units

Cambia Utensile
Quick Changer

Profili e Staffe
Profiles and Brackets

Pinze
Grippers

Attuatori Lineari
Linear Actuators

Sospensioni
Suspensions

Taglierini
Nippers

Kit-Robot
Robot Kit

Accessori Opzionali
Options

Sensori
Sensors

Dimensioni (mm)
Dimensions (mm)

OFS...S

	A	B	C	D	E	F	G	H	J	K	L	M	N	P
OFS20-90S	106	83	92	Ø20	8	M5	2°	11	2.5	13	20	M17x1	6	5
OFS30-90S	159	125	137	Ø30	11	M5	2°	14	4	20	30	M27x1	11	6

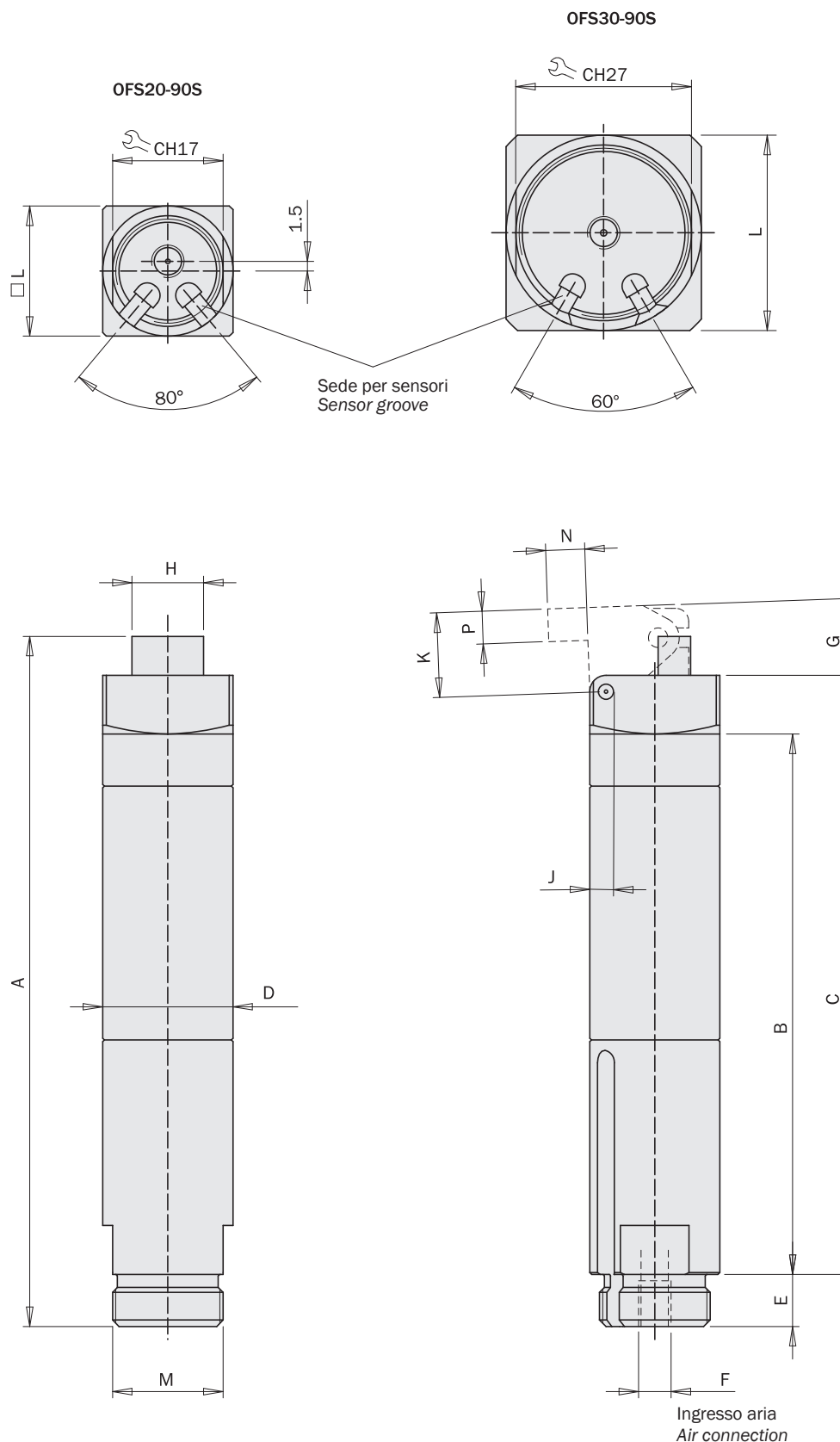

Dimensioni (mm)
Dimensions (mm)

OFR...-95G

	A	B	C	E	F	G	H	I	L	M	N	O	P	Q	R	S	T	U	V
OFR14-95G	Ø14	14	72	45.5	19	12	5.5	M12x1	2	32.5	11	2.5	3	19	-	32	12	7.5	-
OFR20-95G	Ø20	20	103	68.5	25	17.5	8	M17x1	2.5	55.5	15	2.5	4	27.5	-	43.5	17	7	-
OFR30-95G	Ø30	30	148	100	37	25.5	11	M27x1	4	84	20	3	5	40	20	63	27	9	24

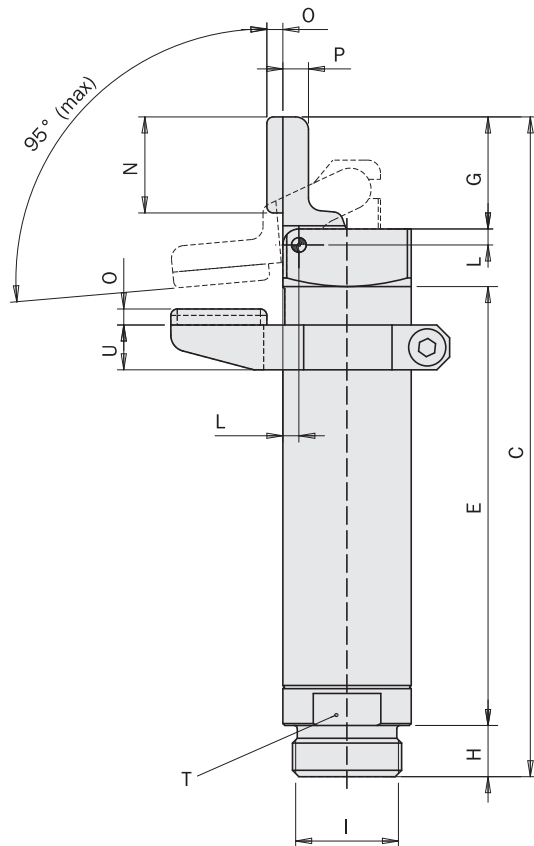
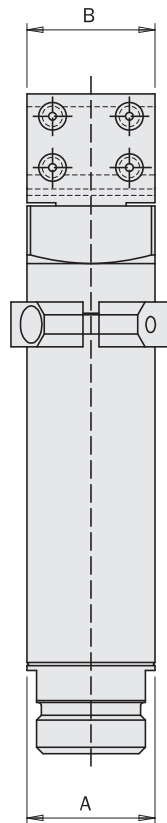
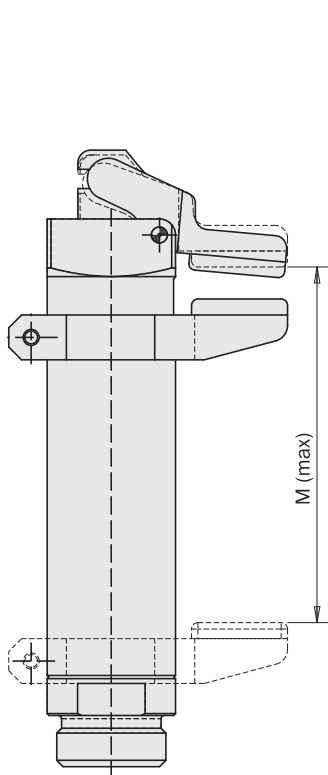
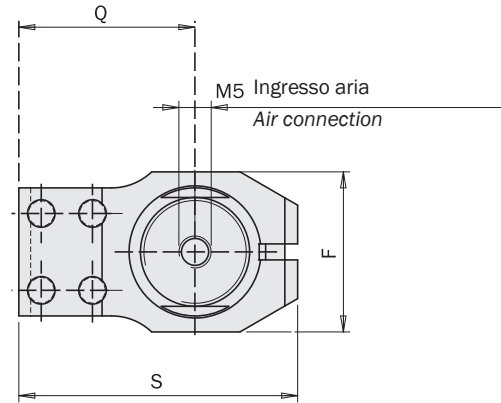
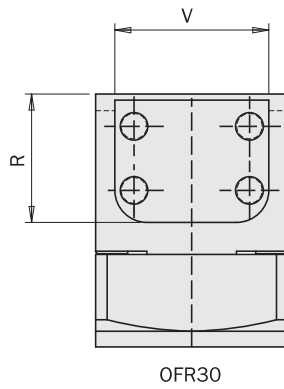

FIRST ANGLE PROJECTION

Dimensioni (mm)
Dimensions (mm)

OFR...-95SG

	A	B	C	D	E	F	G	H	I	K	L	M	N	O	P	Q	R	S	T	U	V
OFR20-95SG	Ø20	20	117.5	1.5	83	25	17.5	8	M17x1	80°	2.5	75	15	2.5	4	27.5	-	43.5	17	7	-
OFR30-95SG	Ø30	30	173	-	124.7	37	25	11	M27x1	60°	4	113	20	3	5	40	20	63	27	9	24

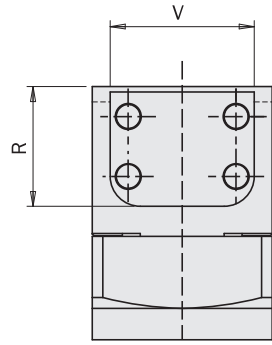

OFR30

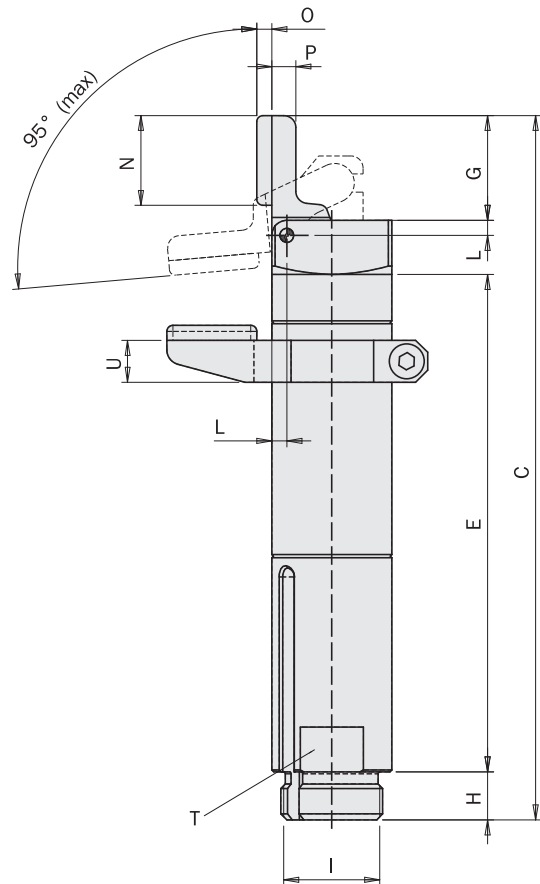
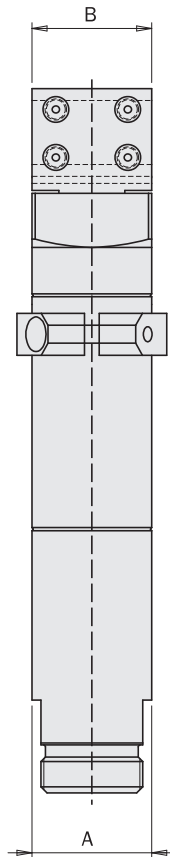
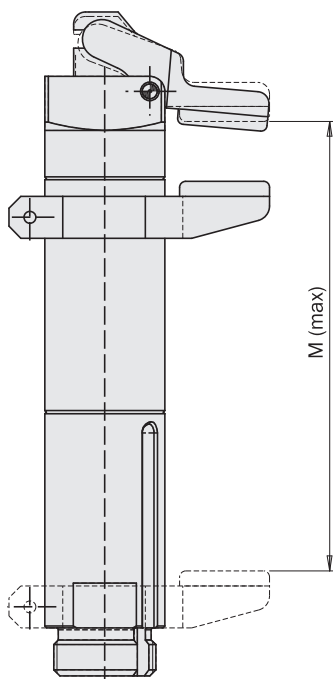
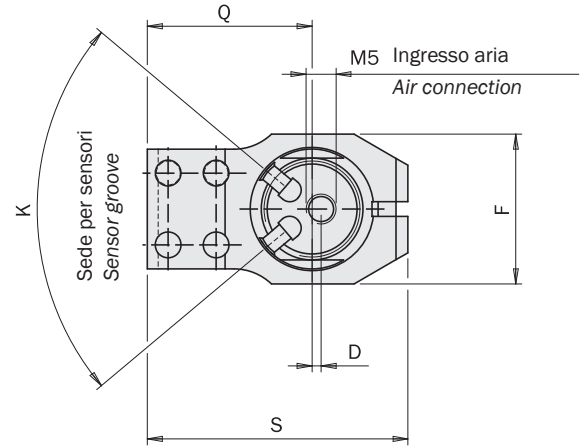

FIRST ANGLE
PROJECTION