



 GOYEN

INDUSTRIAL CONTROL PRODUCTS

CONTENTS

General Information			
.....	3	B6M3 Series	
		Normally Open 3/2	22
Piloted Solenoid Valves		Remote Pilot Valves	
BW Series		BXX and BXB Series	
Normally Closed 2/2	4	Normally Open 2/2	24
BWJ Series		Gas Valves	
Normally Closed 2/2	6	20BAL Series	
BW Series		Normally Closed 2/2	26
Normally Open 2/2	8	QLS and QG Series	
QW and QWJ Series		Normally Closed 2/2	28
Normally Closed 2/2	10	Plastic Appliance Valves	
Direct Lift Solenoid Valves		AD4 and ST2 Series	
Q3M and Q6M Series		Normally Closed 2/2	30
Normally Closed 2/2	12	Solenoid Coils and Enclosures	
B6M Series		Description & Specifications.....	32
Normally Closed 2/2	14	B series dimensions	33
BL Series		Q series dimensions	34
Normally Closed 2/2	16	BH series (Exd).....	35
Q3M Series			
Normally Open 2/2	18		
Q3M3 Series			
Normally Closed 3/2	20		
Q3M3 Series			
Normally Open 3/2	20		
B6M Series			
Normally Open 2/2	22		
B6M3 Series			
Normally Closed 3/2	22		

A COMPREHENSIVE RANGE OF INDUSTRIAL FLUID CONTROL SOLUTIONS

Solenoid operated valves are devices that control the flow of liquids or gases. Goyen manufactures and distributes valves that are designed for specific applications relating to the control of Gas, Fuel, Air, Water or Light Oils.

There are two principal types of operation for solenoid valves – Direct Lift and Pilot Operated.

DIRECT LIFT VALVES – In these models, movement of the plunger directly opens or closes the valve as the sealing disc is attached to the plunger. The valve will operate from zero pressure differential to its maximum rated pressure. Direct Lift Valves are available in normally open or normally closed configuration.

PILOT OPERATED VALVES – These models are equipped with a diaphragm or piston which provides the seal for the main valve orifice. These valves are used to handle much greater flow or pressure requirements than direct-acting valves. Two designs of Pilot Operated valves are available, either a floating diaphragm which requires a small pressure drop across the main valve orifice to remain in the open position, or a coupled diaphragm which is mechanically held open via a direct linkage to the solenoid plunger. The coupled design will operate with zero pressure drop across the main valve orifice.

Both Direct Lift and Pilot Operated Valves are available in normally open or normally closed configuration.

2-WAY VALVES – These valves have one inlet port and one outlet port and are

used as an on/off valve to control the flow of liquids or gases.

3-WAY VALVES – These valves enable the application and release of pressure from closed-end systems, such as the air-piloted operation of hydraulic or pneumatic control valves or single-acting cylinders.

INSTALLATION NOTES

Unless otherwise stated, valves in this catalogue may be installed in any orientation, although it is preferable to mount the solenoid above the valve so as to minimise the ingress of dirt and foreign matter into the ferrule tube. Care should be taken not to use the solenoid enclosure as a lever when installing or removing the valve.

KV AND CV FLOW FACTORS

The CV factor denotes the number of US Gallons of water per minute at 60°F that a valve can pass, with a pressure drop of 1 psi across the main seat.

The metric equivalent of Cv is Kv – cubic metres of water per hour at 20°C with a pressure drop of 1 bar. $Kv = 0.86 Cv$

SPECIAL NOTES

The pressure ratings shown in this catalogue are intended to cover both AC and DC voltages, with hot coils and –15% supply voltages. If your particular requirement exceeds the pressure ratings shown, please contact your nearest Goyen Sales Office for advice. In all cases ambient temperature is taken to be 25°C (77°F).

GOYEN BW SERIES

2/2 NORMALLY CLOSED

Valves are actuated by a solenoid pilot, using an internal bleed. The BW series use a floating diaphragm to provide the seal for the main orifice. The pressure within the valve is utilised to open and close the diaphragm. A small pressure drop across the main orifice is required to keep the diaphragm in the open position.

SPECIFICATIONS

Pressure

Operating pressure range:
20 to 1000 kPa (3 to 150 psi)

Minimum pressure differential:
20 kPa (3 psi)

Fluid Temperatures

Nitrile and Viton seals:
Fluid temperature range
-34°C to +82°C (-29°F to +180°F)

EPDM seals:

Fluid temperature range
0°C to +95°C (+32°F to +203°F)

Ambient Temperatures

-34°C to +40°C (-29°F to +104°F)

Approvals and Standards

ISO 9001 Quality Management System,
Certificate: QEC0366
Watermark certificate number:
WMKA00172
C-Tick Mark, Supplier Code: N282
UL Listing: File YIOZ.MH9011
CE Compliance to Directives
2006/95/EC and 2004/108/EC
RoHS Compliance to Directive
2002/95/EC

Part Number Code: 1 2 B W 2 - E N B N T - 6 0 4 3

Valve Size

6BW2	1/4" pipe thread
10BW2	3/8" pipe thread
12BW2	1/2" pipe thread
20BW2	3/4" pipe thread
25BW3	1" pipe thread
40BW2	1-1/2" pipe thread

Internal Construction

C	For use with DC coils only
E	For use with AC coils only

Special Features

N	No special features
U	UL Listed – General Purpose Valve – (AC coils only)
W	Australian Watermark Approval – (EPDM seals only)
X	Cleaned for Oxygen service – (Viton seals only)

Body Material

B	Brass (DR – Dezincification Resistant)
N	Additional electroless nickel plating

Seal Material

E	EPDM
N	Nitrile
V	Viton

Port Thread

T	RC Thread (BSPT)
A	NPT Thread

Coil Options
See page 32.



CONNECTION AND FLOW

VALVE MODEL	PIPE SIZE		ORIFICE SIZE		FLOW FACTOR	
	MM	INCH	MM	INCH	CV	KV
6BW2	6	1/4	6.4	0.25	1.1	0.95
10BW2	10	3/8	9.5	0.38	2.1	1.81
12BW2	12	1/2	12.7	0.50	3.5	3.01
20BW2	20	3/4	19.0	0.75	7.7	6.62
25BW3	25	1	25.4	1.00	13.2	11.35
40BW2	40	1-1/2	38.1	1.50	24.0	20.64

DIMENSIONS

VALVE MODEL	L		W		H		C		D	
	MM	INCH	MM	INCH	MM	INCH	MM	INCH	MM	INCH
6BW2	55.0	2.17	41.3	1.63	88.0	3.46	27.5	1.08	11.0	0.43
10BW2	55.0	2.17	41.3	1.63	88.0	3.46	27.5	1.08	11.0	0.43
12BW2	72.0	2.83	58.0	2.28	95.0	3.74	36.0	1.42	14.3	0.56
20BW2	89.0	3.50	68.3	2.69	104.0	4.09	44.5	1.75	17.5	0.69
25BW3	120.6	4.75	79.4	3.13	123.0	4.84	52.4	2.06	20.6	0.81
40BW2	156.0	6.14	95.3	3.75	144.0	5.67	78.0	3.07	28.5	1.12

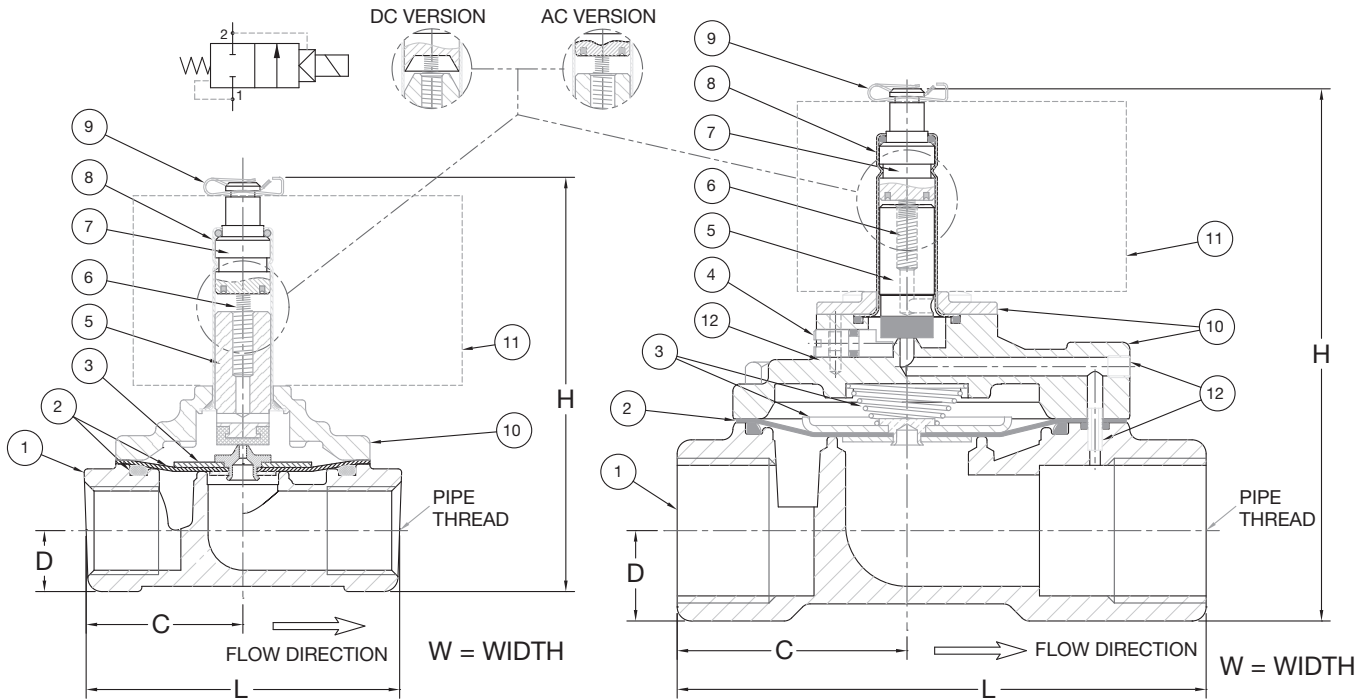

TYPICAL CONSTRUCTION
SIZES 6 TO 20

TYPICAL CONSTRUCTION
SIZES 25 TO 40

CONSTRUCTION

ITEM	DESCRIPTION	MATERIAL
1	Body	486 Brass (DR)
2	Diaphragm & Seals	Nitrile, Viton or EPDM
3	Springs & Washers	304 Stainless Steel
4	Manual Test Shaft	303 Stainless Steel
5	Plunger	430FR Stainless Steel
6	Plunger Spring	304 Stainless Steel
7	Iron Top	430FR Stainless Steel
8	Ferrule Tube	305-4F Stainless Steel
9	Coil Clip	Plated Steel
10	Covers	486 Brass (DR)
11	Coils	Refer to page 32.

SPARE PARTS KITS – STANDARD COILS

Kits consist of plunger, spring, seals and diaphragm

MODEL		NITRILE	VITON	EPDM
6BW2	AC	KM1628	KM1721	KM1725
	DC	KM1656	KM1660	KM1892
10BW2	AC	KM1628	KM1721	KM1725
	DC	KM1656	KM1660	KM1892
12BW2	AC	KM1626	KM1722	KM1726
	DC	KM1657	KM1661	KM1893
20BW2	AC	KM1627	KM1723	KM1727
	DC	KM1658	KM1662	KM1894
25BW3	AC	KM3013	KM3010	KM3011
	DC	KM3017	KM3014	KM3016
40BW2	AC	KM1459	KM1460	KM1462
	DC	KM2423	KM2424	KM2425

SPARE PARTS KITS – BH COILS

Kits consist of plunger, spring, seals and diaphragm

MODEL		NITRILE	VITON	EPDM
12BW2	AC	KM1827	KM1828	KM1829
	DC	KM1830	KM1831	KM1832
20BW2	AC	KM1833	KM1834	KM1835
	DC	KM1836	KM1837	KM1839
25BW3	AC	KM1838	KM1840	KM1841
	DC	KM3838	KM3139	KM3140
40BW2	AC	KM1845	KM1846	KM1847
	DC	KM3141	KM3142	KM3143

GOYEN BWJ SERIES

2/2 NORMALLY CLOSED

Valves are actuated by a solenoid pilot, using an internal bleed. A diaphragm provides the seal for the main orifice. The pressure within the valve is utilised to open and close the diaphragm. The BWJ series use a coupled diaphragm design which is mechanically held open via a direct linkage to the solenoid plunger. This enables the valve to operate with zero pressure differential across the main valve orifice.

SPECIFICATIONS

Pressure

Operating pressure range:

Refer to Table.

Minimum pressure differential:

0 kPa (0 psi)

Fluid Temperatures

Nitrile and Viton seals:

Fluid temperature range

-34°C to +82°C (-29°F to +180°F)

EPDM seals:

Fluid temperature range

0°C to +95°C (+32°F to +203°F)

Ambient Temperatures

-34°C to +40°C (-29°F to +104°F)

Approvals and Standards

ISO 9001 Quality Management System,

Certificate: QEC0366

Watermark certificate number:

WMKA00172

C-Tick Mark, Supplier Code: N282

UL Listing: File YIOZ.MH9011

CE Compliance to Directives

2006/95/EC and 2004/108/EC

RoHS Compliance to Directive

2002/95/EC

Part Number Code:

1 2 B W J 2 - E N B N T - 6 0 4 3

Valve Size

6BWJ2	1/4" pipe thread
10BWJ2	3/8" pipe thread
12BWJ2	1/2" pipe thread
20BWJ2	3/4" pipe thread
25BWJ2	1" pipe thread

Internal Construction

C	For use with DC coils only
E	For use with AC coils only

Special Features

N	No special features
U	UL Listed – General Purpose Valve – (AC coils only)
W	Australian Watermark Approval – (EPDM seals only)
X	Cleaned for Oxygen service – (Viton seals only)

Body Material

B	Brass (DR – Dezincification Resistant)
N	Additional electroless nickel plating

Seal Material

E	EPDM
N	Nitrile
V	Viton

Port Thread

T	RC Thread (BSPT)
A	NPT Thread

Coil Options
See page 32.



OPERATING PRESSURE RANGE

VALVE MODEL	PRESSURE	
	KPA	PSI
6BWJ2	0 to 1000	0 to 150
10BWJ2	0 to 1000	0 to 150
12BWJ2	0 to 1000	0 to 150
20BWJ2	0 to 700	0 to 100
25BWJ2	0 to 400	0 to 60

CONNECTION AND FLOW

VALVE MODEL	PIPE SIZE		ORIFICE SIZE		FLOW FACTOR	
	MM	INCH	MM	INCH	CV	KV
6BWJ2	6	1/4	6.4	0.25	1.1	0.95
10BWJ2	10	3/8	9.5	0.38	2.1	1.81
12BWJ2	12	1/2	12.7	0.50	3.5	3.01
20BWJ2	20	3/4	19.0	0.75	7.7	6.62
25BWJ2	25	1	25.4	1.00	13.2	11.35

DIMENSIONS

VALVE MODEL	L		W		H		C		D	
	MM	INCH	MM	INCH	MM	INCH	MM	INCH	MM	INCH
6BWJ2	55.0	2.17	41.3	1.63	88.0	3.46	27.5	1.08	11.0	0.43
10BWJ2	55.0	2.17	41.3	1.63	88.0	3.46	27.5	1.08	11.0	0.43
12BWJ2	72.0	2.83	58.0	2.28	95.0	3.74	36.0	1.42	14.3	0.56
20BWJ2	89.0	3.50	68.3	2.69	104.0	4.09	44.5	1.75	17.5	0.69
25BWJ2	105.0	4.13	79.4	3.13	111.0	4.37	52.5	2.07	20.6	0.81

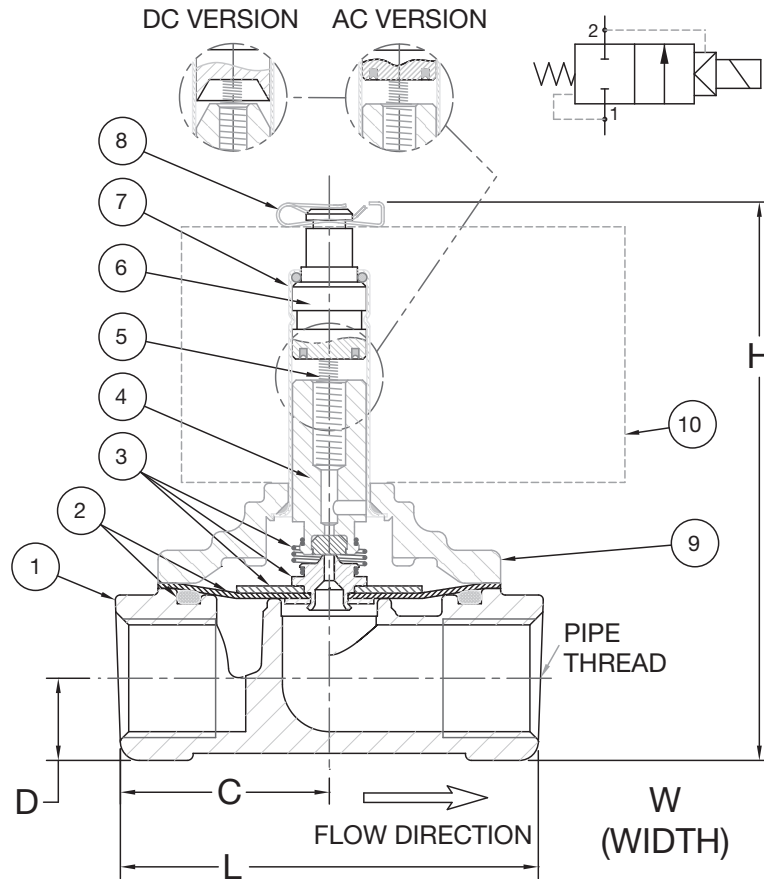

TYPICAL CONSTRUCTION

CONSTRUCTION

ITEM	DESCRIPTION	MATERIAL
1	Body	486 Brass [DR]
2	Diaphragm & Seals	Nitrile, Viton or EPDM
3	Springs & Washers	304 Stainless Steel
4	Plunger	430FR Stainless Steel
5	Plunger Spring	304 Stainless Steel
6	Iron Top	430FR Stainless Steel
7	Ferrule Tube	305-4F Stainless Steel
8	Coil Clip	Plated Steel
9	Cover	486 Brass [DR]
10	Coils	Refer to page 32.

SPARE PARTS KITS – STANDARD COILS

Kits consist of plunger, springs, seals and diaphragm

MODEL		NITRILE	VITON	EPDM
6BWJ2	AC	KM1584	KM1596	KM1600
	DC	KM1664	KM1668	KM1918
10BWJ2	AC	KM1584	KM1596	KM1600
	DC	KM1664	KM1668	KM1918
12BWJ2	AC	KM1585	KM1597	KM1601
	DC	KM1665	KM1669	KM1919
20BWJ2	AC	KM1586	KM1598	KM1602
	DC	KM1666	KM1670	KM1920
25BWJ2	AC	KM1587	KM1599	KM1603
	DC	KM1667	KM1671	KM1921

SPARE PARTS KITS – BH COILS

Kits consist of plunger, springs, seals and diaphragm

MODEL		NITRILE	VITON	EPDM
12BWJ2	AC	KM1946	KM1947	KM3164
	DC	KM3158	KM3159	KM3160
20BWJ2	AC	KM1948	KM1949	KM3165
	DC	KM3161	KM3162	KM3163

GOYEN BW SERIES

2/2 NORMALLY OPEN

Valves are actuated by a solenoid pilot, using an internal bleed. The BW Normally Open series use a floating diaphragm to provide the seal for the main orifice. The pressure within the valve is utilised to open and close the diaphragm. A small pressure drop across the main orifice is required to keep the diaphragm in the open (normal) position. When the solenoid is energised, the fluid pressure closes the diaphragm.

SPECIFICATIONS

Pressure

Operating pressure range:
20 to 1000 kPa (3 to 150 psi)

Minimum pressure differential:
20 kPa (3 psi)

Fluid Temperatures

Nitrile and Viton seals:
Fluid temperature range
-34°C to +82°C (-29°F to +180°F)

EPDM seals:

Fluid temperature range
0°C to +95°C (+32°F to +203°F)

Ambient Temperatures

-34°C to +40°C (-29°F to +104°F)

Approvals and Standards

ISO 9001 Quality Management System,
Certificate: QEC0366
Watermark certificate number:
WMKA00172
C-Tick Mark, Supplier Code: N282
UL Listing: File YIOZ.MH9011
CE Compliance to Directives
2006/95/EC and 2004/108/EC
RoHS Compliance to Directive
2002/95/EC

Part Number Code:

1 2 B W 2 - B N B N T - 6 0 4 3

Valve Size

12BW2	1/2" pipe thread
20BW2	3/4" pipe thread
25BW3	1" pipe thread
40BW2	1-1/2" pipe thread

Construction

B Normally Open, for use with either AC or DC coils

Special Features

N	No special features
U	UL Listed – General Purpose – (Size 12, AC coils only)
W	Australian Watermark Approval – (EPDM seals only)
X	Cleaned for Oxygen service – (Viton seals only)

Body Material

B	Brass (DR – Dezincification Resistant)
N	Additional electroless nickel plating

Seal Material

E	EPDM
N	Nitrile
V	Viton

Port Thread

T	RC Thread (BSPT)
A	NPT Thread

Coil Options
See page 32.



CONNECTION AND FLOW

VALVE MODEL	PIPE SIZE		ORIFICE SIZE		FLOW FACTOR	
	MM	INCH	MM	INCH	CV	KV
12BW2	12	1/2	12.7	0.50	3.5	3.01
20BW2	20	3/4	19.0	0.75	7.7	6.62
25BW3	25	1	25.4	1.00	13.2	11.35
40BW2	40	1-1/2	38.1	1.50	24.0	20.64

DIMENSIONS

VALVE MODEL	L		W		H		C		D	
	MM	INCH	MM	INCH	MM	INCH	MM	INCH	MM	INCH
12BW2	87.3	3.44	58.0	2.28	110.0	4.33	36.0	1.42	14.3	0.56
20BW2	104.8	4.13	68.3	2.69	118.0	4.65	44.5	1.75	17.5	0.69
25BW3	120.6	4.75	79.4	3.13	127.0	5.00	52.4	2.06	20.6	0.81
40BW2	156.0	6.14	95.3	3.75	148.0	5.83	78.0	3.07	28.5	1.12

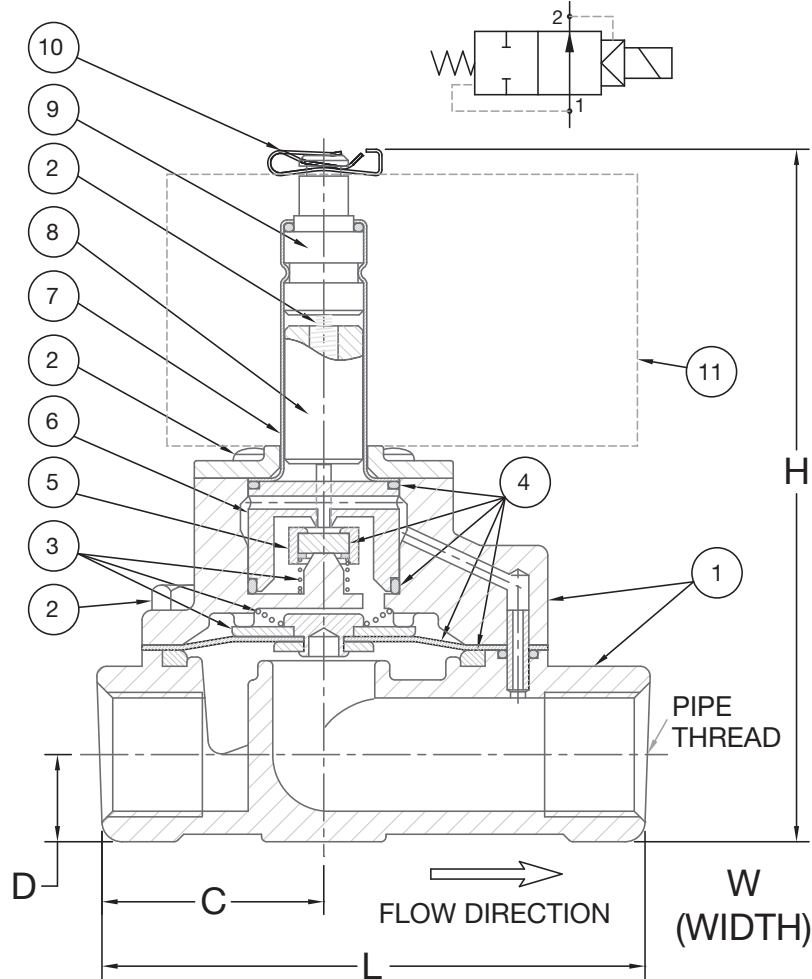

TYPICAL CONSTRUCTION
SHOWN IN NORMAL (OPEN) POSITION

CONSTRUCTION

ITEM	DESCRIPTION	MATERIAL
1	Body & covers	486 Brass [DR]
2	Screws	304 Stainless Steel
3	Springs & Washers	304 Stainless Steel
4	Seals & O-Rings	Nitrile, Viton or EPDM
5	Valve Stem	Nylon 66
6	Valve Insert	486 Brass [DR]
7	Ferrule Tube	305-4F Stainless Steel
8	Plunger	430FR Stainless Steel
9	Iron Top	430FR Stainless Steel [Copper Ring]
10	Coil Clip	Plated Steel
11	Coils	Refer to page 32.

SPARE PARTS KITS – MAIN VALVE

Kits consist of diaphragm, diaphragm spring and seals.

MODEL	NITRILE	VITON	EPDM
12BW2	KM1783	KM1784	KM1785
20BW2	KM1928	KM1929	KM1930
25BW3	KM1647	KM1648	KM1649
40BW2	KM1786	KM1787	KM1788

SPARE PARTS KITS – PILOT

Kits consist of plunger, valve stem, springs and seals.

MODEL	NITRILE	VITON	EPDM
All Sizes	KM1789	KM1790	KM1791

GOYEN QW AND QWJ SERIES

2/2 NORMALLY CLOSED

Valves are actuated by a solenoid pilot, using an internal bleed. The pressure within the valve is utilised to open and close the diaphragm. The QW series use a floating diaphragm to provide the seal for the main orifice. A small pressure drop across the main orifice is required to keep the diaphragm in the open position. The QWJ series use a coupled diaphragm design which is mechanically held open via a direct linkage to the solenoid plunger. This enables the valve to operate with zero pressure differential across the main valve orifice.

SPECIFICATIONS

Pressure

Operating pressure range:

Refer to Table.

Minimum pressure differential:

QW 20 kPa (3 psi)

QWJ 0 kPa (0 psi)

Fluid Temperatures

Nitrile and Viton seals:

Fluid temperature range

-34°C to +82°C (-29°F to +180°F)

EPDM seals:

Fluid temperature range

0°C to +95°C (+32°F to +203°F)

Ambient Temperatures

-34°C to +40°C (-29°F to +104°F)

Approvals and Standards

ISO 9001 Quality Management System,

Certificate: QEC0366

Watermark certificate number:

WMKA00172

C-Tick Mark, Supplier Code: N282

UL Files: YIOZ.MH9011

YIOZ2.MH9011

CE Compliance to Directives

2006/95/EC and 2004/108/EC

RoHS Compliance to Directive

2002/95/EC

Part Number Code:

1 2 Q W J 2 - E N B N T - 7 0 4 3

Valve Size

6	1/4" pipe thread
10	3/8" pipe thread
12	1/2" pipe thread

Diaphragm Option

QW	Floating diaphragm
QWJ	Coupled diaphragm

Internal Construction

C	For use with DC coils only
E	For use with AC coils only

Special Features

N	No special features
E	UL Recognized Component (QW AC coils only)
U	UL Listed – General Purpose Valve (QW AC coils only)
W	Australian Watermark Approval – (EPDM seals only)
X	Cleaned for Oxygen service – (Viton seals only)

Body Material

B	Brass (DR – Dezincification Resistant)
N	Additional electroless nickel plating

Seal Material

E	EPDM
N	Nitrile
V	Viton

Port Thread

T	RC Thread (BSPT)
A	NPT Thread

Coil Options
See page 32.



OPERATING PRESSURE RANGE

VALVE MODEL	PRESSURE	
	KPA	PSI
6QW2	20 to 1000	3 to 150
10QW2	20 to 1000	3 to 150
12QW2	20 to 1000	3 to 150
6QWJ2	0 to 1000	0 to 150
10QWJ2	0 to 1000	0 to 150
12QWJ2	0 to 1000	0 to 150

CONNECTION AND FLOW

VALVE MODEL	PIPE SIZE		ORIFICE SIZE		FLOW FACTOR	
	MM	INCH	MM	INCH	CV	KV
6QW2 6QWJ2	6	1/4	6.4	0.25	1.1	0.95
10QW2 10QWJ2	10	3/8	9.5	0.38	2.1	1.81
12QW2 12QWJ2	12	1/2	12.7	0.50	3.5	3.01

DIMENSIONS

VALVE MODEL	L		W		H		C		D	
	MM	INCH	MM	INCH	MM	INCH	MM	INCH	MM	INCH
6QW2 6QWJ2	55.0	2.17	41.3	1.63	83.0	3.27	27.5	1.08	11.0	0.43
10QW2 10QWJ2	55.0	2.17	41.3	1.63	89.0	3.50	27.5	1.08	11.0	0.43
12QW2 12QWJ2	72.0	2.83	58.0	2.28	89.0	3.50	36.0	1.42	14.3	0.56

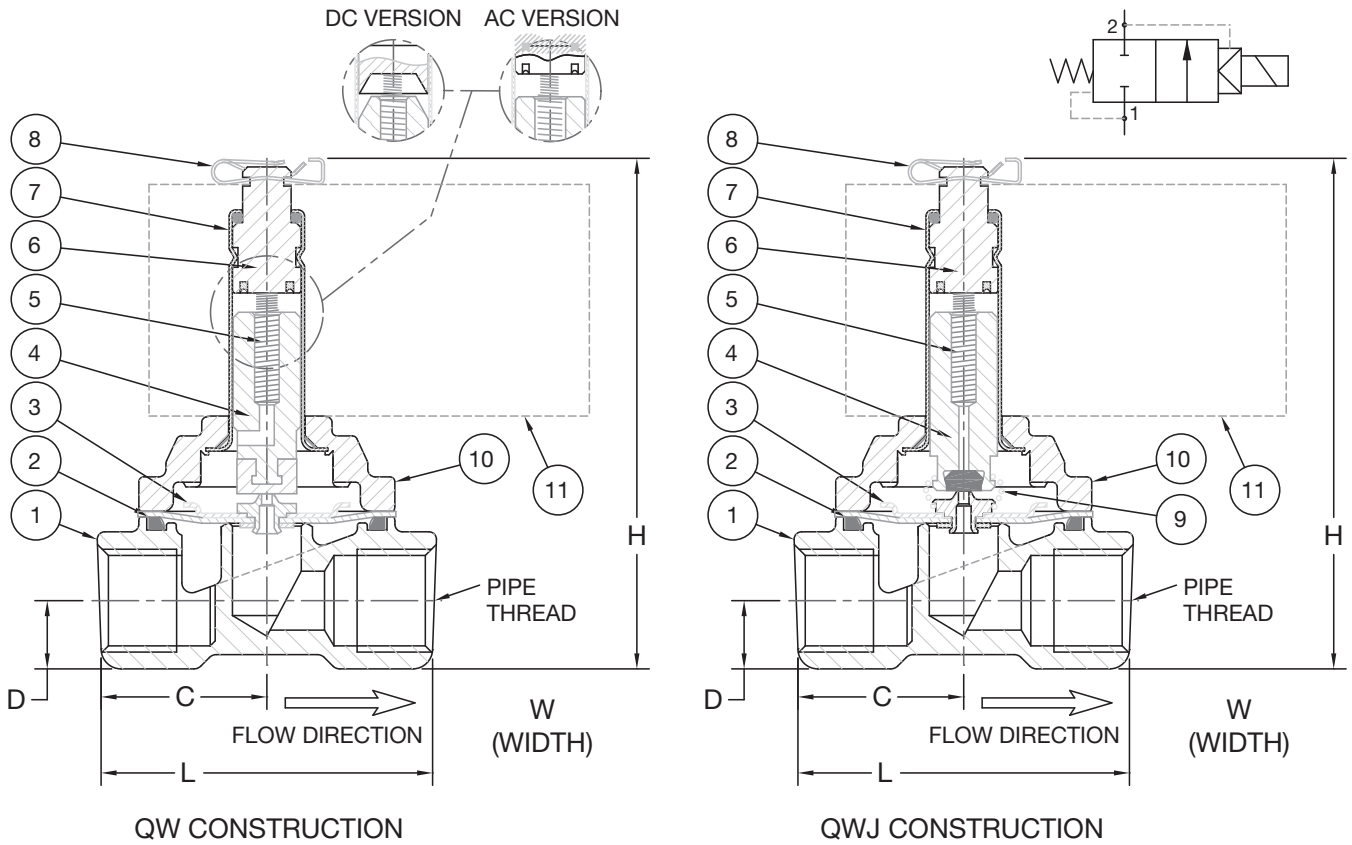

SPARE PARTS KITS

Kits consist of plunger, springs, seals and diaphragm.

MODEL		NITRILE	VITON	EPDM
6QW2	AC	KM1870	KM1958	KM1959
	DC	KM2020	KM2021	KM2022
10QW2	AC	KM1870	KM1958	KM1959
	DC	KM2020	KM2021	KM2022
12QW2	AC	KM1905	KM1960	KM1961
	DC	KM2499	KM3149	KM3021
6QWJ2	AC	KM2029	KM2120	KM2121
	DC	KM1988	KM2122	KM3131
10QWJ2	AC	KM2029	KM2120	KM2121
	DC	KM1988	KM2122	KM3131
12QWJ2	AC	KM2054	KM2123	KM2127
	DC	KM3086	KM2125	KM2126

CONSTRUCTION

ITEM	DESCRIPTION	MATERIAL
1	Body	486 Brass [DR]
2	Diaphragm & Seats	Nitrile, Viton or EPDM
3	Springs & Washers	304 Stainless Steel
4	Plunger	430FR Stainless Steel
5	Plunger Spring	304 Stainless Steel
6	Iron Top	430FR Stainless Steel
7	Ferrule Tube	305-4F Stainless Steel
8	Coil Clip	Plated Steel
9	Diaphragm Spring (QWJ2)	304 Stainless Steel
10	Cover	486 Brass [DR]
11	Coils	Refer to page 32.

GOYEN Q3M AND Q6M SERIES

2/2 NORMALLY CLOSED

Valves are actuated by a direct solenoid. Maximum operating pressure is proportional to the orifice size. A smaller orifice enables a higher operating pressure.

SPECIFICATIONS

Pressure

Operating pressure range:

Refer to Table.

Minimum pressure differential:

0 kPa (0 psi)

Fluid Temperatures

Nitrile and Viton seals:

Fluid temperature range

-34°C to +82°C (-29°F to +180°F)

EPDM seals:

Fluid temperature range

0°C to +95°C (+32°F to +203°F)

Ambient Temperatures

-34°C to +40°C (-29°F to +104°F)

Approvals and Standards

ISO 9001 Quality Management System, Certificate: QEC0366

Watermark certificate number: WMKA00172

AGA Certificate: 2870 AS4629 Class 1 (1Q6M and all Q3M)

C-Tick Mark, Supplier Code: N282

UL Files YIOZ.MH9011

YIOZ2.MH9011

CE Compliance to Directives

2006/95/EC and 2004/108/EC

RoHS Compliance to Directive

2002/95/EC

Part Number Code:

4 Q 3 M - A N B N T - 7 0 4 3

Orifice Size

1	1.6 mm (0.062")	Q3M	Q6M
2	2.4 mm (0.093")	Q3M	-
3	2.8 mm (0.109")	Q3M	-
4	3.2 mm (0.125")	Q3M	Q6M
6	6.4 mm (0.250")	-	Q6M

Valve Size

Q3M	1/8" Pipe Thread
Q6M	1/4" Pipe Thread

Internal Construction

A	Normally closed, for use with either AC or DC coils
---	---

Special Features

N	No special features
1	Class 1 Australian Gas Approval (Brass/Alum, Nitrile/Viton)
E	UL Recognised Component (Q3M, Brass, AC coils only)
U	UL Listed (Q3M, Brass, AC coils only)
W	Australian Watermark Approval (Brass-EPDM only)
X	Cleaned for Oxygen service (Viton seals only)

Body Material

A	Aluminium – Alloy 2011
B	Brass – Alloy 352 (DR – Dezincification Resistant)
N	Brass with electroless nickel plating
H	Acetal (Delrin)
S	Stainless Steel – Alloy 303

Seal Material

E	EPDM
N	Nitrile
V	Viton

Port Thread

T	RC Thread (BSPT) – brass, nickel-plated and aluminium bodies
P	RP Thread (BSPP) – acetal and stainless steel bodies
A	NPT Thread – all body materials

Coil Options
See page 32.



OPERATING PRESSURE RANGE

VALVE MODEL	PRESSURE	
	KPA	PSI
1Q3M	0 to 2550	0 to 370
2Q3M	0 to 1000	0 to 150
3Q3M	0 to 700	0 to 100
4Q3M	0 to 500	0 to 75
1Q6M	0 to 2550	0 to 370
4Q6M	0 to 500	0 to 75
6Q6M	0 to 80	0 to 12

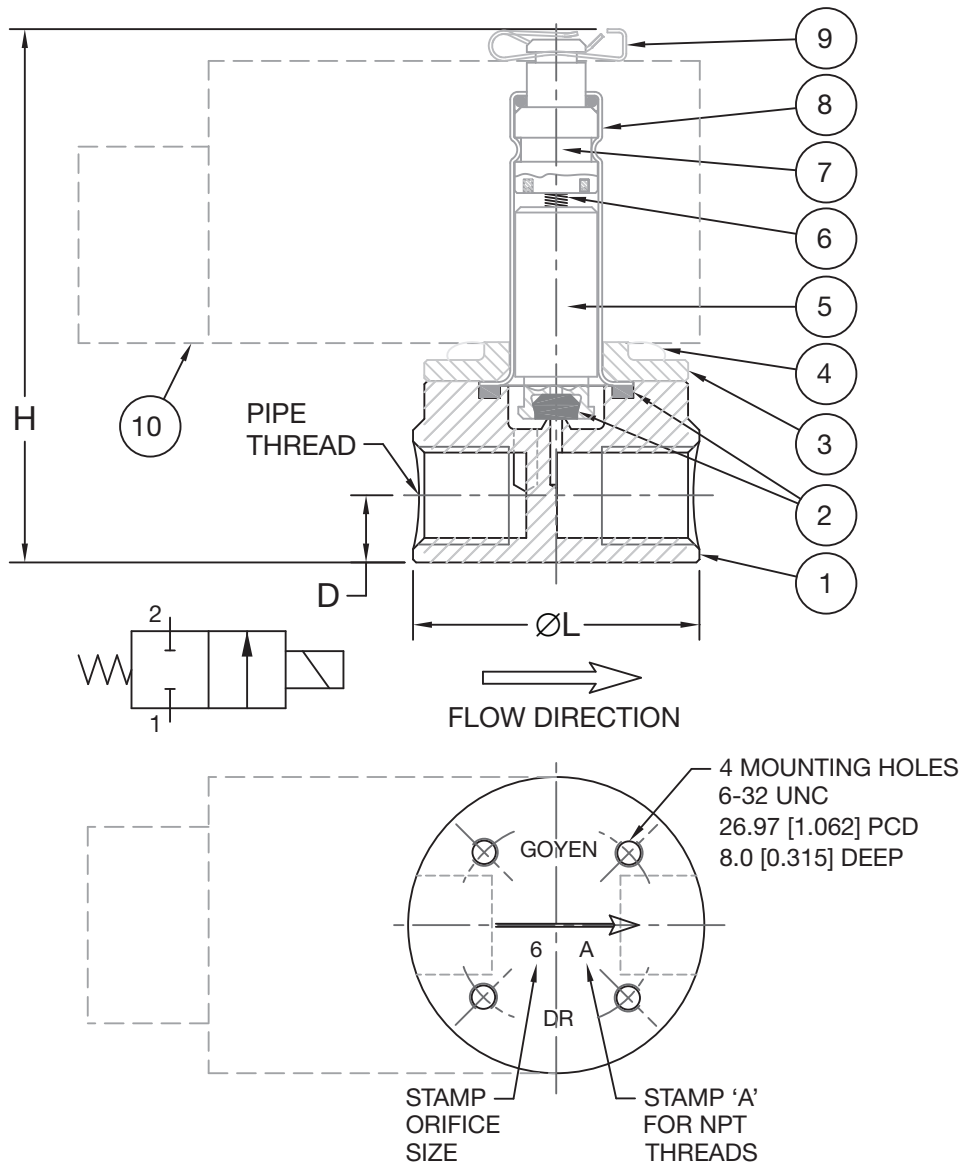

DIMENSIONS

VALVE MODEL	PIPE THREAD	ØL		H		D	
		MM	INCH	MM	INCH	MM	INCH
Q3M	1/8"	35.0	1.37	65.0	2.56	7.4	0.29
Q6M	1/4"	38.0	1.50	70.0	2.76	8.7	0.34

CONSTRUCTION

ITEM	DESCRIPTION	MATERIAL
1	Body	See part number code
2	Seals	Nitrile, Viton or EPDM
3	Ferrule Retainer	Same as body material
4	Screws	302 Stainless Steel
5	Plunger	430FR Stainless Steel
6	Plunger Spring	304 Stainless Steel
7	Iron-Top	430FR Stainless Steel
8	Ferrule Tube	305-4F Stainless Steel
9	Coil Clip	Plated steel
10	Coil Assembly	Refer to page 32.

CONNECTION AND FLOW

VALVE MODEL	PIPE SIZE		ORIFICE SIZE		FLOW FACTOR	
	MM	INCH	MM	INCH	CV	KV
1Q3M	3	1/8	1.6	0.062	0.1	0.09
2Q3M	3	1/8	2.4	0.093	0.2	0.17
3Q3M	3	1/8	2.8	0.109	0.3	0.26
4Q3M	3	1/8	3.2	0.125	0.5	0.43
1Q6M	6	1/4	1.6	0.062	0.1	0.09
4Q6M	6	1/4	3.2	0.125	0.5	0.43
6Q6M	6	1/4	6.4	0.250	0.7	0.60

SPARE PARTS KITS

Kits consist of plunger, spring and seals.

MODEL	NITRILE	VITON	EPDM
Q3M	KM1347	KM1348	KM1469
Q6M	KM2149	KM2147	KM2148

GOYEN B6M SERIES

2/2 NORMALLY CLOSED

Valves are actuated by a direct solenoid. Maximum operating pressure is proportional to the orifice size. A smaller orifice enables a higher operating pressure.

SPECIFICATIONS

Pressure

Operating pressure range:

Refer to Table.

Minimum pressure differential:

0 kPa (0 psi)

Fluid Temperatures

Nitrile and Viton seals:

Fluid temperature range

-34°C to +82°C (-29°F to +180°F)

EPDM seals:

Fluid temperature range

0°C to +95°C (+32°F to +203°F)

Ambient Temperatures

-34°C to +40°C (-29°F to +104°F)

Approvals and Standards

ISO 9001 Quality Management System, Certificate: QEC0366

Watermark certificate number: WMKA00172

AGA Certificate: 2501 AS4629 Class 1

C-Tick Mark, Supplier Code: N282

UL Listing: File YIOZ.MH9011

CE Compliance to Directives

2006/95/EC and 2004/108/EC

RoHS Compliance to Directive

2002/95/EC

Part Number Code:

4 B 6 M - E N B N T - 6 0 4 3

Orifice Size

1	1.6 mm (0.062")
2	2.4 mm (0.093")
4	3.2 mm (0.125")
5	4.8 mm (0.187")
6	6.0 mm (0.235")

Valve Size

B6M 1/4" Pipe Thread

Internal Construction

C	For use with DC coils only
E	For use with AC coils only

Special Features

N	No special features
1	Class 1 Australian Gas Approval (Brass-Nitrile only)
U	UL Listed (Brass, Stainless Steel, AC coils only)
W	Australian Watermark Approval (Brass-EPDM only)
X	Cleaned for Oxygen service (Viton seals only)

Body Material

B	Brass – Alloy 352 (DR – Dezincification Resistant)
N	Brass with electroless nickel plating
H	Acetal (Delrin)
S	Stainless Steel – Alloy 303

Seal Material

E	EPDM
N	Nitrile
V	Viton

Port Thread

T	RC Thread (BSPT) – brass and nickel-plated bodies only
P	RP Thread (BSPP) – acetal and stainless steel bodies only
A	NPT Thread – all body materials

Coil Options
See page 32.



OPERATING PRESSURE RANGE

VALVE MODEL	PRESSURE	
	KPA	PSI
1B6M	0 to 2100	0 to 300
2B6M	0 to 1200	0 to 175
4B6M	0 to 1000	0 to 150
5B6M	0 to 400	0 to 60
6B6M	0 to 200	0 to 30

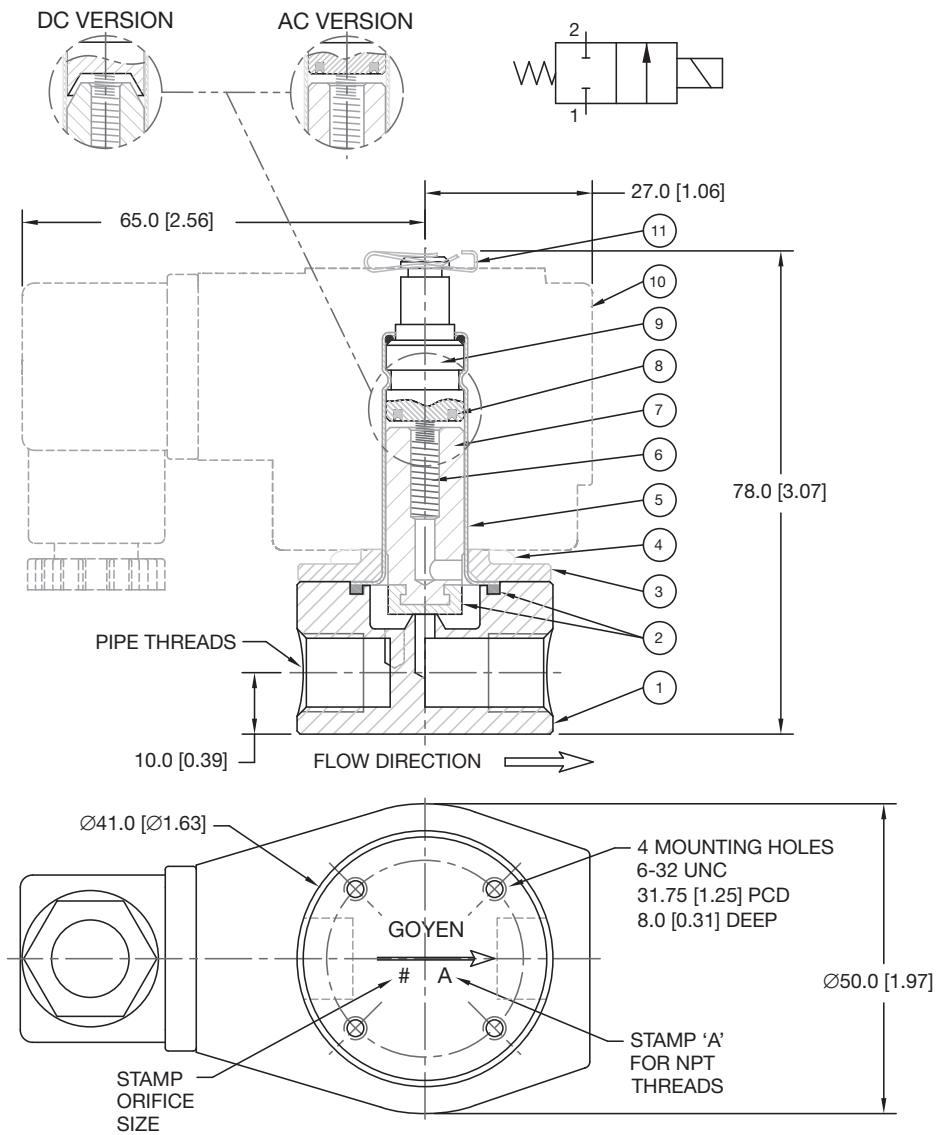

DIMENSIONS IN MILLIMETRES [INCHES]

CONSTRUCTION

ITEM	DESCRIPTION	MATERIAL
1	Body	See part number code
2	Seals	Nitrile, Viton or EPDM
3	Ferrule Retainer	Same as body material
4	Screws	302 Stainless Steel
5	Ferrule Tube	305-4F Stainless Steel
6	Plunger Spring	304 Stainless Steel
7	Plunger	430FR Stainless Steel
8	Shading Ring	Copper 110 A (AC version)
9	Iron-Top	430FR Stainless Steel
10	Coil Assembly	Refer to page 32.
11	Coil Clip	Plated Steel

CONNECTION AND FLOW

VALVE MODEL	PIPE SIZE		ORIFICE SIZE		FLOW FACTOR	
	MM	INCH	MM	INCH	CV	KV
1B6M	6	1/4	1.6	0.062	0.1	0.09
2B6M	6	1/4	2.4	0.093	0.2	0.17
4B6M	6	1/4	3.2	0.125	0.3	0.26
5B6M	6	1/4	4.8	0.187	0.5	0.43
6B6M	6	1/4	6.0	0.235	0.7	0.60

SPARE PARTS KITS – STANDARD COILS

Kits consist of plunger, spring and seals

MODEL		NITRILE	VITON	EPDM
All B6M	AC	KM1349	KM1350	KM1408
	DC	KM2447	KM2448	KM2449

SPARE PARTS KITS – BH COILS

Kits consist of plunger, spring and seals

MODEL		NITRILE	VITON	EPDM
All B6M	AC	KM1821	KM1822	KM1823
	DC	KM3135	KM3136	KM3137

GOYEN BL SERIES

2/2 NORMALLY CLOSED

Valves are actuated by a direct solenoid. Maximum operating pressure is proportional to the orifice size. A smaller orifice enables a higher operating pressure. BL series valves are designed for high-flow, low-pressure applications. Valves are suitable for use with air, gas, water or light oil.

SPECIFICATIONS

Pressure

Operating pressure range: Refer to Table.

Minimum pressure differential: 0 kPa (0 psi)

Fluid Temperature Range

Nitrile seals:
-34°C to +82°C (-29°F to +180°F)

Ambient Temperatures

-34°C to +40°C (-29°F to +104°F)

Approved Gases

UL: Fuel Gas, Natural Gas, Propane
AGA: Town Gas, Natural Gas, LPG, TLP, SNG

Approvals and Standards

ISO 9001 Quality Management System, Certificate: QEC0366
UL Files: YIOZ.MH9011 YIOZ2.MH9011
AGA Certificate: 2501 AS4629 Class 1 C-Tick Mark, Supplier Code: N282
CE Compliance to Directives 2006/95/EC and 2004/108/EC
RoHS Compliance to Directive 2002/95/EC

Part Number Code:

1 2 B L 2 - E N B N T - 6 0 4 3

Valve Size

10	3/8" pipe thread
12	1/2" pipe thread
20	3/4" pipe thread
25	1" pipe thread

Valve Series

BL2 High-flow, low-pressure

Internal Construction

C	For use with DC coils only
E	For use with AC coils only

Special Features

N	No special features
1	Class 1 Australian Gas Approval (size 10 & 12 only)
E	UL Recognized Component
U	UL Listed – General Purpose Valve

Body Material

B	Brass (DR – Dezincification Resistant)
N	Additional electroless nickel plating

Seal Material

N	Nitrile
----------	---------

Port Thread

T	RC Thread (BSPT)
A	NPT Thread

Coil Options
See page 32.



OPERATING PRESSURE RANGE

VALVE MODEL	PRESSURE	
	KPA	PSI
10BL2	0 to 70	0 to 10
12BL2	0 to 40	0 to 6
20BL2	0 to 10	0 to 1.5
25BL2	0 to 3.5	0 to 0.5

CONNECTION AND FLOW

VALVE MODEL	PIPE SIZE		ORIFICE SIZE		FLOW FACTOR	
	MM	INCH	MM	INCH	CV	KV
10BL2	10	3/8	9.5	0.38	2.1	1.81
12BL2	12	1/2	12.7	0.50	3.5	3.01
20BL2	20	3/4	19.0	0.72	7.7	6.62
25BL2	25	1	25.4	1.00	13.2	11.35

DIMENSIONS

VALVE MODEL	L		W		H		C		D	
	MM	INCH	MM	INCH	MM	INCH	MM	INCH	MM	INCH
10BL2	55.0	2.17	41.3	1.63	88.0	3.46	27.5	1.08	11.0	0.43
12BL2	72.0	2.83	58.0	2.28	95.0	3.74	36.0	1.42	14.3	0.56
20BL2	89.0	3.50	68.3	2.69	104.0	4.09	44.5	1.75	17.5	0.69
25BL2	105.0	4.13	79.4	3.13	111.0	4.37	52.4	2.07	20.6	0.81

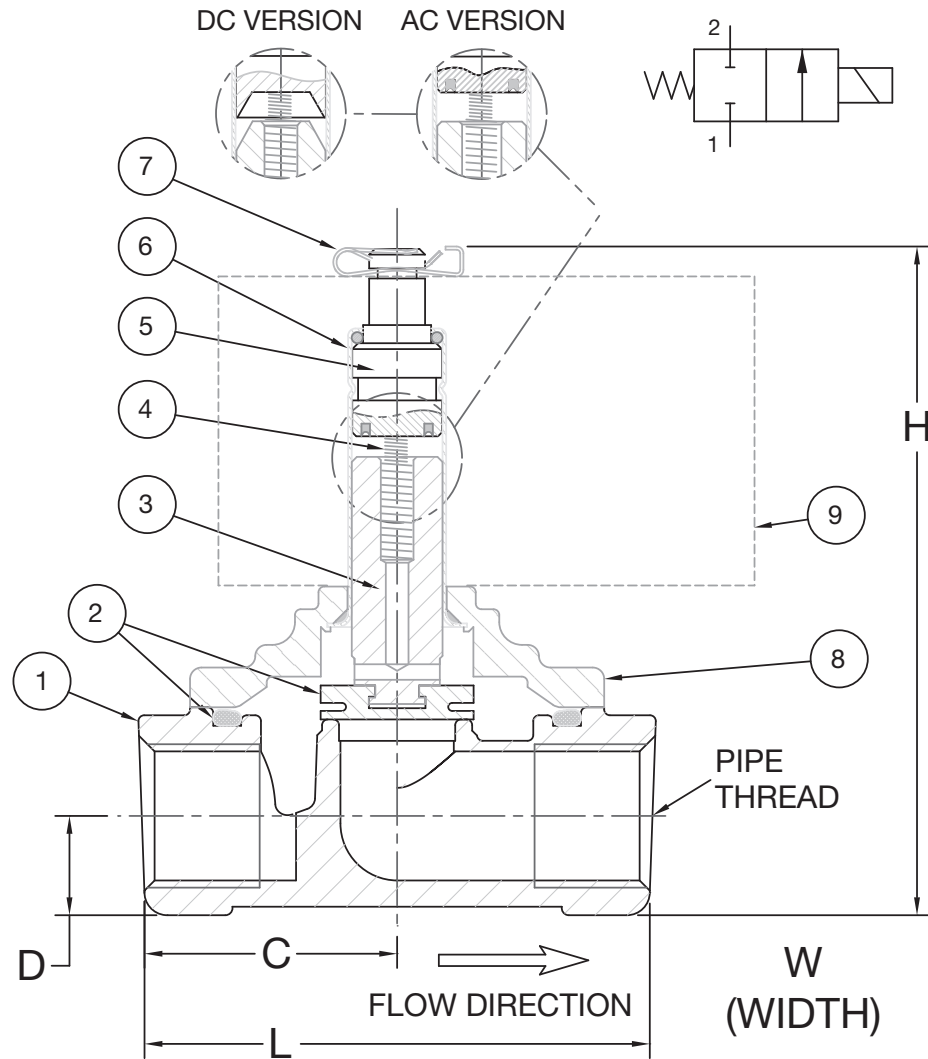

BL2 TYPICAL CONSTRUCTION

CONSTRUCTION

ITEM	DESCRIPTION	MATERIAL
1	Body	486 Brass (DR)
2	Seals	Nitrile Rubber
3	Plunger	430FR Stainless Steel
4	Plunger Spring	304 Stainless Steel
5	Iron Top	430FR Stainless Steel
6	Ferrule Tube	305-4F Stainless Steel
7	Coil Clip	Plated Steel
8	Cover	486 Brass (DR)
9	Coils	Refer to page 32.

SPARE PARTS KITS

Kits consist of plunger, spring and seals.

MODEL		KIT (NITRILE SEALS)
10BL2	AC	KM1423
	DC	KM3113
12BL2	AC	KM1427
	DC	KM3105
20BL2	AC	KM1439
	DC	KM1882
25BL2	AC	KM1447
	DC	KM1872

GOYEN Q3M SERIES

2/2 NORMALLY OPEN

Valves are actuated by a direct solenoid. Maximum operating pressure is proportional to the orifice size. A smaller orifice enables a higher operating pressure. Valves are suitable for use with air, water or light oil. Energising the coil stops fluid flow. De-energising the coil allows fluid to flow.

SPECIFICATIONS

Pressure

Operating pressure range:

Refer to Table.

Minimum pressure differential:

0 kPa (0 psi)

Ambient Temperatures

-34°C to +40°C [-29°F to +104°F]

Fluid Temperatures

Nitrile and Viton seals:

Fluid temperature range

-34°C to +82°C [-29°F to +180°F]

EPDM seals:

Fluid temperature range 0°C to +95°C (+32°F to +203°F)

Approvals and Standards

ISO 9001 Quality Management System, Certificate: QEC0366

Watermark certificate number: WMKA00172

C-Tick Mark, Supplier Code: N282

CE Compliance to Directives

2006/95/EC and 2004/108/EC

RoHS Compliance to Directive

2002/95/EC

Part Number Code:

2 Q 3 M - F N B N T - 7 0 4 3

Orifice Size

1	1.6 mm (0.062")
2	2.4 mm (0.093")
4	3.2 mm (0.125")

Valve Size

Q3M 1/8" pipe thread

Internal Construction

D	Normally open, DC coils only
F	Normally open, AC coils only

Special Features

N	No special features
W	Australian Watermark Approval (Brass & EPDM only)
X	Cleaned for Oxygen service (Viton seals only)

Body Material

A	Aluminium – Alloy 2011
B	Brass – Alloy 352 (DR – Dezincification Resistant)
N	Brass with electroless nickel plating
H	Acetal (Delrin)
S	Stainless Steel – Alloy 303

Seal Material

E	EPDM
N	Nitrile
V	Viton

Port Thread

T RC Thread (BSPT) – brass, nickel-plated and aluminium bodies only

Coil Options
See page 32.



OPERATING PRESSURE RANGE

VALVE ORIFICE	PRESSURE	
	KPA	PSI
1	0 to 860	0 to 125
2	0 to 400	0 to 60
4	0 to 200	0 to 30

DIMENSIONS

VALVE MODEL	PIPE THREAD	ØL		H		D	
		MM	INCH	MM	INCH	MM	INCH
Q3M 2/2 N/O	1/8"	38.1	1.50	76.5	3.01	17.8	0.70

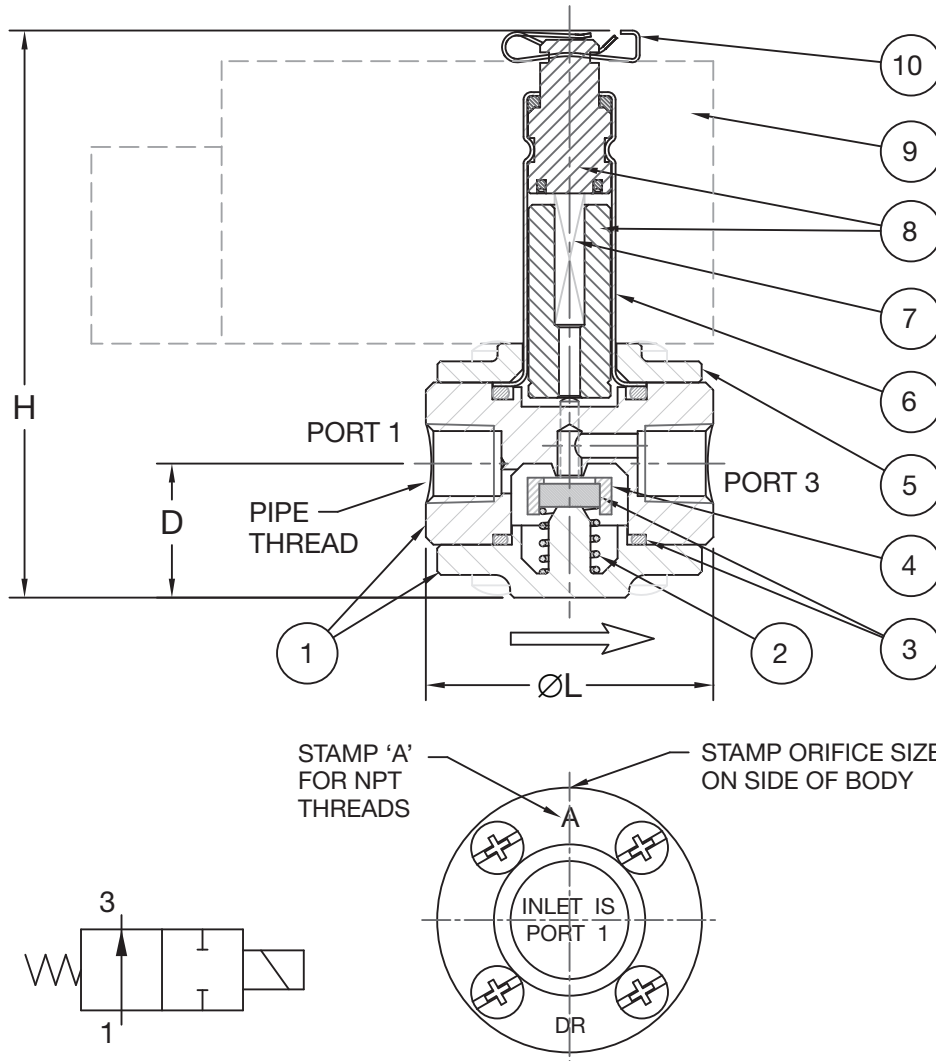

Q3M 2/2 NORMALLY OPEN CONSTRUCTION

CONNECTION AND FLOW

VALVE ORIFICE	PIPE SIZE		ORIFICE SIZE		FLOW FACTOR	
	MM	INCH	MM	INCH	CV	KV
1	3	1/8	1.6	0.062	0.1	0.09
2	3	1/8	2.4	0.093	0.2	0.17
4	3	1/8	3.2	0.125	0.3	0.26

SPARE PARTS KITS

Kits consist of plunger, spring and seals.

MODEL	NITRILE	VITON	EPDM
Q3M 2/2 N/O	KM2551	KM2552	KM2553

Q3M 2/2 N/O CONSTRUCTION

ITEM	DESCRIPTION	MATERIAL
1	Body and Seat	See part number code
2	Valve Spring	304 Stainless Steel
3	Seals	Nitrile, Viton or EPDM
4	Valve	Polyamide 66
5	Ferrule Retainer	Same as body material
6	Ferrule Tube	305-4F Stainless Steel
7	Plunger Spring	304 Stainless Steel
8	Plunger and Iron-top	430FR Stainless Steel
9	Coil Assembly	Refer to page 32.
10	Coil Clip	Plated steel

GOYEN Q3M3 SERIES

3/2 NORMALLY CLOSED OR NORMALLY OPEN

Valves are actuated by a direct solenoid. Maximum operating pressure is proportional to the orifice size. A smaller orifice enables a higher operating pressure. The Q3M3 is Normally Closed and used with air only. The exhaust hole is through the top of the solenoid. The Q3M3T valves have a threaded exhaust port. They are suitable for use with air, water or light oil and are configured either Normally Open or Normally Closed.

SPECIFICATIONS

Pressure

Operating pressure range:

Refer to Table.

Minimum pressure differential:

0 kPa (0 psi)

Ambient Temperatures

-34°C to +40°C (-29°F to +104°F)

Fluid Temperatures

Nitrile and Viton seals:

Fluid temperature range

-34°C to +82°C (-29°F to +180°F)

EPDM seals:

Fluid temperature range

0°C to +95°C (+32°F to +203°F)

Approvals and Standards

ISO 9001 Quality Management System,

Certificate: QEC0366

Watermark certificate number:

WMKA00172

C-Tick Mark, Supplier Code: N282

UL Listing: File YIOZ.MH9011

CE Compliance to Directives

2006/95/EC and 2004/108/EC

RoHS Compliance to Directive

2002/95/EC

Part Number Code:

2 Q 3 M 3 T - E N B N T - 7 0 4 3

Orifice Size

1	1.6 mm (0.062")
2	2.4 mm (0.093")
4	3.2 mm (0.125")

Valve Size

Q3M3	1/8" pipe thread, exhaust through the iron-top
Q3M3T	1/8" pipe thread, exhaust port in the body

Internal Construction

A	Normally closed, AC or DC coils (Q3M3)
C	Normally closed, DC coils only (Q3M3T)
D	Normally open, DC coils only (Q3M3T)
E	Normally closed, AC coils only (Q3M3T)
F	Normally open, AC coils only (Q3M3T)

Special Features

P	Q3M3 only, exhaust through the iron-top
N	No special features (Q3M3T)
U	UL Listed (Brass, Stainless Steel, Q3M3T only)
W	Australian Watermark Approval (Brass, EPDM, Q3M3T only)
X	Cleaned for Oxygen service (Viton seals, Q3M3T only)

Body Material

B	Brass – Alloy 352 (DR – Dezincification Resistant)
N	Brass with electroless nickel plating
H	Acetal (Delrin)
S	Stainless Steel – Alloy 303

Seal Material

E	EPDM
N	Nitrile
V	Viton

Port Thread

T	RC Thread (BSPT) – brass and nickel-plated bodies only
P	RP Thread (BSPP) – acetal and stainless steel bodies only
A	NPT Thread – all body materials

Coil Options
See page 32.



Q3M3



Q3M3T

OPERATING PRESSURE RANGE

VALVE ORIFICE	PRESSURE	
	KPA	PSI
1	0 to 860	0 to 125
2	0 to 400	0 to 60
4	0 to 200	0 to 30

DIMENSIONS

VALVE MODEL	PIPE THREAD	ØL		H		D	
		MM	INCH	MM	INCH	MM	INCH
Q3M3	1/8"	34.9	1.37	65.0	2.56	8.4	0.33
Q3M3T	1/8"	38.1	1.50	87.0	3.42	29.7	1.17

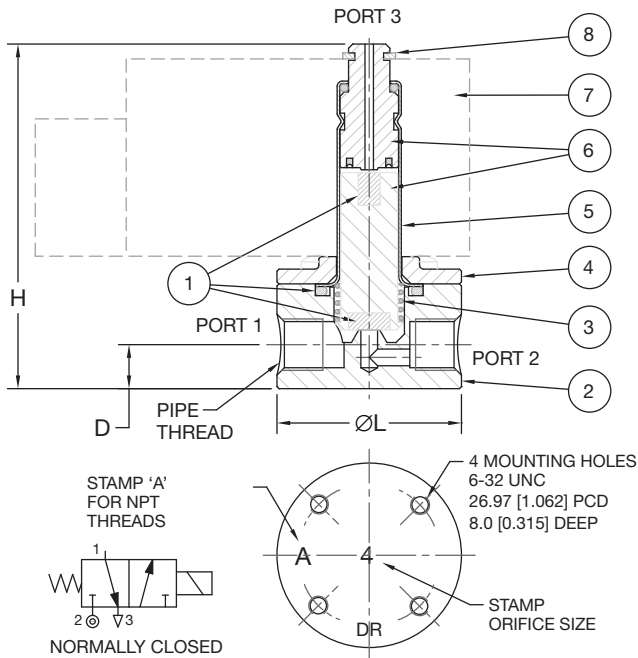

Q3M3 CONSTRUCTION

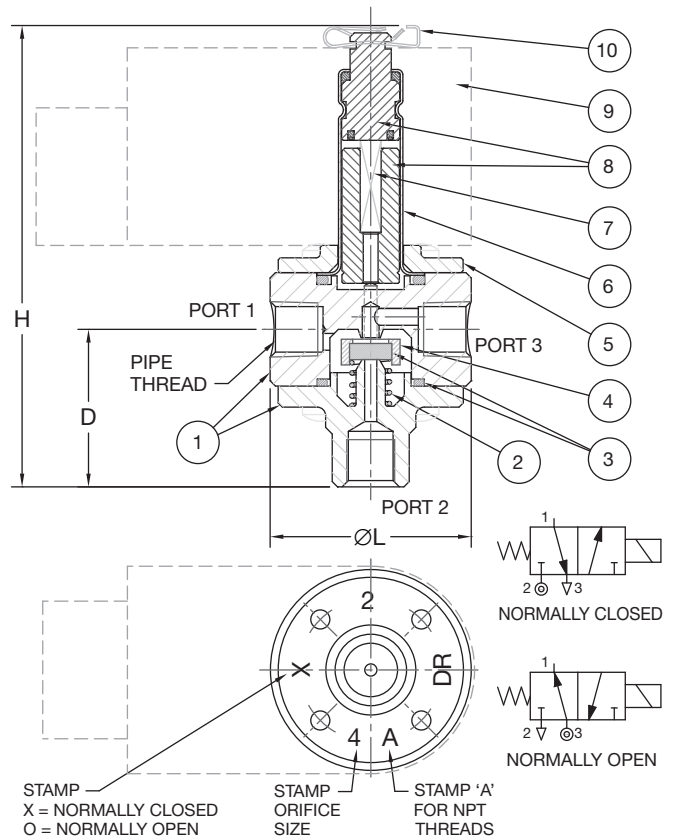

Q3M3T CONSTRUCTION

Q3M3 CONSTRUCTION

ITEM	DESCRIPTION	MATERIAL
1	Seals	Nitrile or Viton
2	Body	See part number code
3	Plunger Spring	304 Stainless Steel
4	Ferrule Retainer	Same as body material
5	Ferrule Tube	305-4F Stainless Steel
6	Plunger and Iron-top	430FR Stainless Steel
7	Coil Assembly	Refer to page 32.
8	Coil Clip	304 Stainless Steel

CONNECTION AND FLOW

VALVE ORIFICE	PIPE SIZE		ORIFICE SIZE		FLOW FACTOR	
	MM	INCH	MM	INCH	CV	KV
1	3	1/8	1.6	0.062	0.1	0.09
2	3	1/8	2.4	0.093	0.2	0.17
4	3	1/8	3.2	0.125	0.3	0.26

SPARE PARTS KITS

Kits consist of plunger, spring and seals.

MODEL	NITRILE	VITON	EPDM
Q3M3	KM1699	KM1792	-
Q3M3T - NC	KM2450	KM2452	KM2454
Q3M3T - NO	KM2551	KM2552	KM2553

Q3M3T CONSTRUCTION

ITEM	DESCRIPTION	MATERIAL
1	Body and Seat	See part number code
2	Valve Spring*	304 Stainless Steel
3	Seals	Nitrile, Viton or EPDM
4	Valve	Polyamide 66
5	Ferrule Retainer	Same as body material
6	Ferrule Tube	305-4F Stainless Steel
7	Plunger Spring*	304 Stainless Steel
8	Plunger and Iron-top	430FR Stainless Steel
9	Coil Assembly	Refer to page 32.
10	Coil Clip	Plated Steel

* Note: Valves are not interchangeable between normally open and normally closed. Different springs are used.

PORT DESIGNATION*

PORT	NORMALLY CLOSED	NORMALLY OPEN
Inlet	Port 2	Port 3
Outlet	Port 1	Port 1
Exhaust	Port 3	Port 2

* Note: Valves are not interchangeable between normally open and normally closed. Different springs are used.

GOYEN B6M SERIES

3/2 NORMALLY CLOSED OR NORMALLY OPEN 2/2 NORMALLY OPEN

Valves are actuated by a direct solenoid. Maximum operating pressure is proportional to the orifice size. A smaller orifice enables a higher operating pressure. They are suitable for use with air, water or light oil. The B6M3 valves have a threaded exhaust port and are configured either normally open or normally closed. 2-port normally open valves are also available.

SPECIFICATIONS

Pressure

Operating pressure range:

Refer to Table.

Minimum pressure differential:

0 kPa (0 psi)

Ambient Temperatures

-34°C to +40°C (-29°F to +104°F)

Fluid Temperatures

Nitrile and Viton seals:

Fluid temperature range

-34°C to +82°C (-29°F to +180°F)

EPDM seals:

Fluid temperature range

0°C to +95°C (+32°F to +203°F)

Approvals and Standards

ISO 9001 Quality Management System, Certificate: QEC0366

Watermark certificate number: WMKA00172

C-Tick Mark, Supplier Code: N282

UL Listing: File YIOZ.MH9011

CE Compliance to Directives

2006/95/EC and 2004/108/EC

RoHS Compliance to Directive

2002/95/EC

Part Number Code:

1 B 6 M 3 - B N B N T - 6 0 4 3

Orifice Size

1	1.6 mm (0.062")
2	2.4 mm (0.093")
4	3.2 mm (0.125")

Valve Size

B6M 1/4" pipe thread

Number of Ports

Blank 2 ports (normally open)
3 3 ports

Internal Construction

A Normally closed, 3/2 valves only
B Normally open, 2/2 and 3/2 valves

Special Features

N No special features
U UL Listed (for AC coils only)
W Australian Watermark Approval (Brass with EPDM only)
X Cleaned for Oxygen service (Viton seals only)

Body Material

B Brass - Alloy 352 (DR - Dezincification Resistant)
N Brass with electroless nickel plating
S Stainless Steel - Alloy 303

Seal Material

E EPDM
N Nitrile
V Viton

Port Thread

T RC Thread (BSPT) - brass and nickel-plated bodies only
P RP Thread (BSPP) - stainless steel bodies only

Coil Options
See page 32.



OPERATING PRESSURE RANGE

VALVE TYPE	VALVE ORIFICE	PRESSURE	
		KPA	PSI
2/2 NO	1	0 to 2100	0 to 300
	2	0 to 1200	0 to 175
	4	0 to 1000	0 to 150
3/2 NO & NC	1	0 to 860	0 to 125
	2	0 to 400	0 to 60
	4	0 to 200	0 to 30

CONNECTION AND FLOW

VALVE ORIFICE	PIPE SIZE		ORIFICE SIZE		FLOW FACTOR	
	MM	INCH	MM	INCH	CV	KV
1	6	1/4	1.6	0.062	0.1	0.09
2	6	1/4	2.4	0.093	0.2	0.17
4	6	1/4	3.2	0.125	0.3	0.26

DIMENSIONS

VALVE MODEL	PIPE THREAD	ØL		H		C		D		E		ØF	
		MM	INCH	MM	INCH	MM	INCH	MM	INCH	MM	INCH	MM	INCH
B6M3	1/4"	44.5	1.75	101.0	3.98	8.8	0.35	28.2	1.11	8.0	0.31	19.0	0.75
B6M	1/4"	44.5	1.75	91.0	3.58	-	-	7.6	0.30	8.0	0.31	19.0	0.75

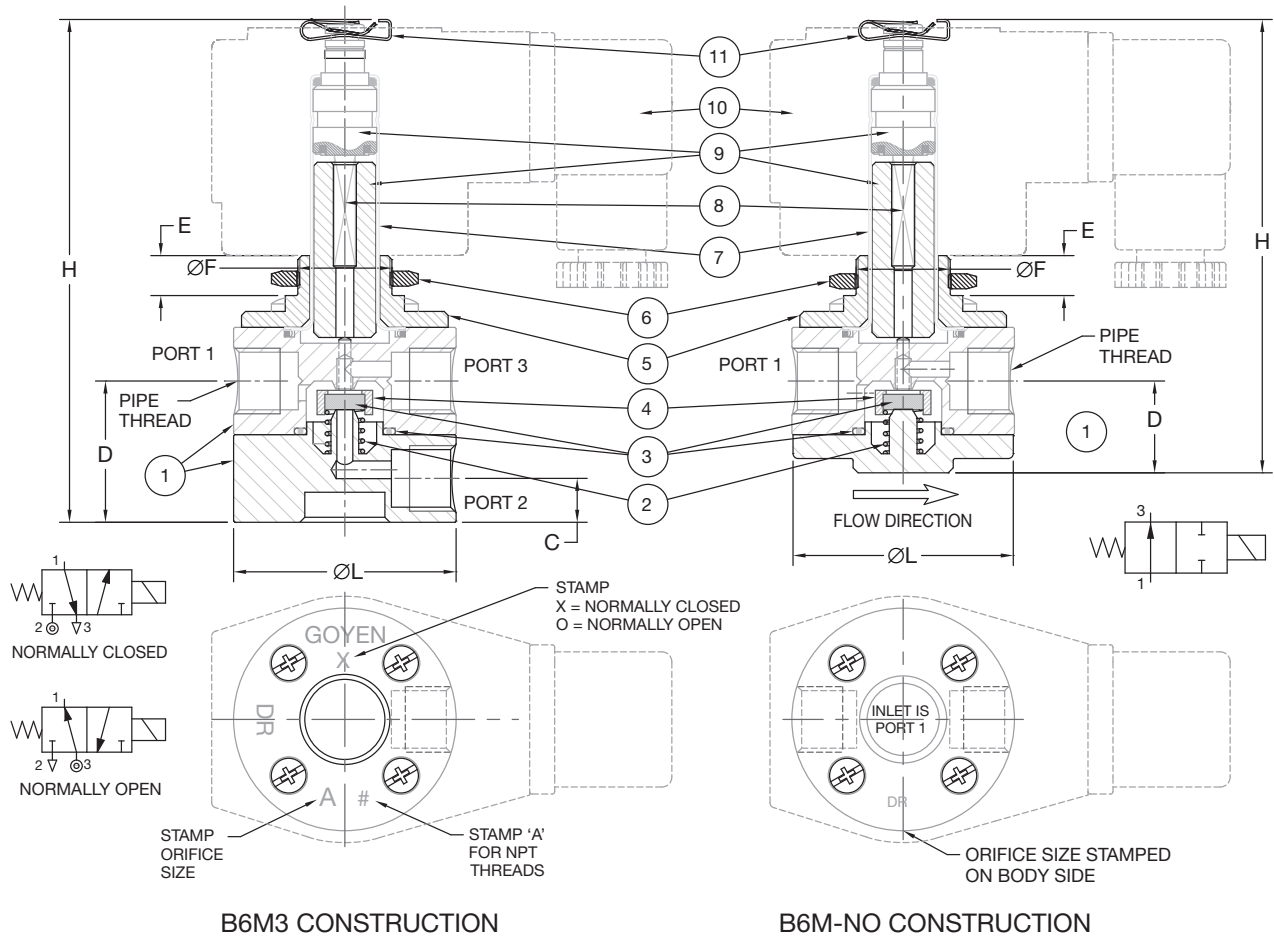

B6M3 CONSTRUCTION

B6M-NO CONSTRUCTION

PORT DESIGNATION (B6M3)*

PORT	NORMALLY CLOSED	NORMALLY OPEN
Inlet	Port 2	Port 3
Outlet	Port 1	Port 1
Exhaust	Port 3	Port 2

* Note: Valves are not interchangeable between normally open and normally closed. Different springs are used.

SPARE PARTS KITS – STANDARD COILS

Kits consist of plunger, springs and seals

MODEL	NITRILE	VITON	EPDM
B6M – NO	KM1336	KM1413	KM1415
B6M3 – NO	KM1336	KM1413	KM1415
B6M3 – NC	KM1337	KM1416	KM1418

SPARE PARTS KITS – BH COILS

Kits consist of plunger, springs and seals

MODEL	NITRILE	VITON	EPDM
B6M – NO	KM1815	KM1816	KM1817
B6M3 – NO	KM1815	KM1816	KM1817
B6M3 – NC	KM1818	KM1819	KM1820

CONSTRUCTION

ITEM	DESCRIPTION	MATERIAL
1	Body and Seat	See part number code
2	Valve Spring*	304 Stainless Steel
3	Seals	Nitrile, Viton or EPDM
4	Valve	Polyamide 66
5	Ferrule Retainer	Same as body material
6	Locknut 3.0mm (0.12") thick	Plated steel
7	Ferrule Tube	305-4F Stainless Steel
8	Plunger Spring*	304 Stainless Steel
9	Plunger and Iron-top	430FR Stainless Steel
10	Coil Assembly	Refer to page 32.
11	Coil Clip	Plated steel

* Note: Valves are not interchangeable between normally open and normally closed. Different springs are used.

GOYEN BXX AND BXB SERIES

2/2 NORMALLY OPEN

Valves are normally open, requiring pressure at the pilot port to close. The BXX series requires an external pilot supply pressure equal to the inlet pressure to close. Pilot over-pressure should be avoided or diaphragm life may be reduced. The pilot signal is isolated from the process fluid and can be of a different medium to the process fluid. Pilot valves must have a 3/2 function to exhaust the pilot signal. The BXB series have a bleed hole in the diaphragm and use the process fluid to close the valve. This allows the use of a 2/2 pilot valve. Caution: Process

fluid carried through the valve will be exhausted through the pilot valve.

SPECIFICATIONS

Pressure

Operating pressure range:

Refer to Table.

Minimum pressure differential:

Refer to Table.

Fluid Temperatures

Nitrile and Viton seals:

Fluid temperature range

-34°C to +82°C [-29°F to +180°F]

EPDM seals:

Fluid temperature range

0°C to +95°C [+32°F to +203°F]

Ambient Temperatures Same as fluid temperatures

Approvals and Standards

ISO 9001 Quality Management System,

Certificate: QEC0366

Watermark certificate number:

WMKA00172

RoHS Compliance to Directive

2002/95/EC

Part Number Code:

1 2 B X X 2 - N W B E T

Valve Size

6	1/4" pipe thread
10	3/8" pipe thread
12	1/2" pipe thread
20	3/4" pipe thread
25	1" pipe thread
40	1-1/2" pipe thread (BXX only)

Valve Type

BXX	Pilot separate from valve fluid
BXB	Pilot uses valve fluid (diaphragm bleed hole)

Series Revision

2	All valves except size 20
3	Size 20 valve only

Construction Type

N	Pneumatic actuated valve (no solenoid)
----------	--

Special Features

N	No special features
W	Australian Watermark Approval – (BXX with EPDM seals only)
X	Cleaned for Oxygen service – (Viton seals only)

Body Material

B	Brass (DR – Dezincification Resistant)
N	Additional electroless nickel plating

Seal Material

E	EPDM
N	Nitrile
V	Viton

Port Thread

T	RC Thread (BSPT)
A	NPT Thread

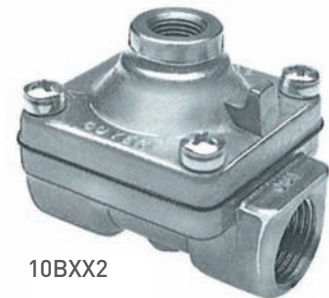

10BXX2

OPERATING PRESSURE RANGE

VALVE MODEL	PRESSURE	
	KPA	PSI
BXX *	70 to 1000	10 to 150
BXB	20 to 1000	3 to 150

* Note: Minimum pilot pressure is equal to the inlet pressure

CONNECTION AND FLOW

VALVE SIZE	PIPE SIZE		ORIFICE SIZE		FLOW FACTOR	
	MM	INCH	MM	INCH	CV	KV
6	6	1/4	6.4	0.25	1.1	0.95
10	10	3/8	9.5	0.38	2.1	1.81
12	12	1/2	12.7	0.50	3.5	3.01
20	20	3/4	19.0	0.75	7.7	6.62
25	25	1	25.4	1.00	13.2	11.35
40	40	1-1/2	38.1	1.50	24.0	20.64

DIMENSIONS

VALVE MODEL	PORT THREAD	PILOT THREAD	L		W		H		C		D	
			MM	INCH	MM	INCH	MM	INCH	MM	INCH	MM	INCH
6BXX 6BXB	1/4" pipe thread	1/8" pipe thread	55.0	2.17	41.3	1.63	45.0	1.77	27.5	1.08	11.0	0.43
10BXX 10BXB	3/8" pipe thread	1/8" pipe thread	55.0	2.17	41.3	1.63	45.0	1.77	27.5	1.08	11.0	0.43
12BXX 12BXB	1/2" pipe thread	1/8" pipe thread	72.0	2.83	58.0	2.28	62.0	2.44	36.0	1.42	14.3	0.56
20BXX 20BXB	3/4" pipe thread	1/8" pipe thread	89.0	3.50	68.3	2.69	72.0	2.83	44.5	1.75	17.5	0.69
25BXX 25BXB	1" pipe thread	1/8" pipe thread	105.0	4.13	79.4	3.13	82.0	3.23	52.5	2.07	20.6	0.81
40BXX 40BXB	1-1/2" pipe thread	1/4" pipe thread	156.0	6.14	95.3	3.75	92.0	3.62	78.0	3.07	28.5	1.12

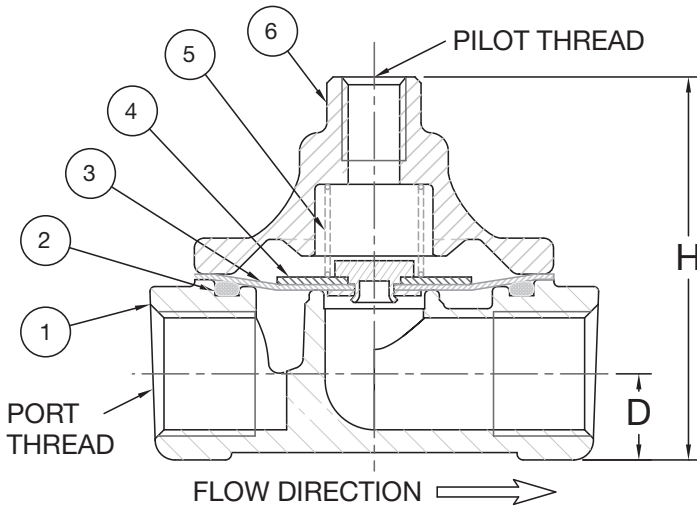
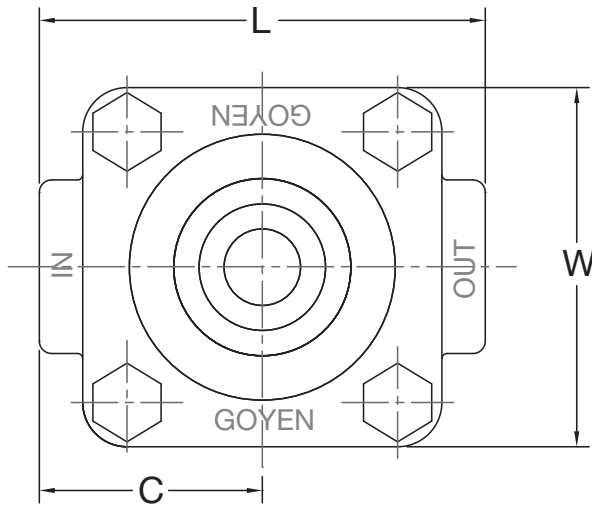

TYPICAL CONSTRUCTION

12BXX2 SHOWN

SPARE PARTS KITS – BXX SERIES

Kits consist of spring, seal and diaphragm.

MODEL	NITRILE	VITON	EPDM
6BXX2	KM1208A	KM1521	KM2392
10BXX2	KM1208A	KM1521	KM2392
12BXX2	KM1211A	KM1773	KM1991
20BXX2*	KM3146C	KM3147C	KM3148C
20BXX3	KM3146	KM3147	KM3148
25BXX2	KM1518	KM1524	KM1993
40BXX2	KM3019	KM3151	KM3152

* Conversion kit from 20BXX2 to 20BXX3

BXX SCHEMATIC

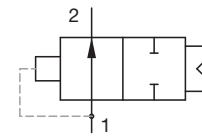

BXX VALVE

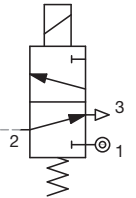

PILOT VALVE

BXB SCHEMATIC

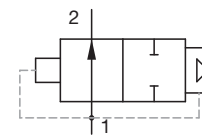

BXB VALVE

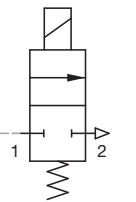

PILOT VALVE

CONSTRUCTION

ITEM	DESCRIPTION	MATERIAL
1	Body	486 Brass (DR)
2	Sealing Ring	Nitrile, Viton or EPDM
3	Diaphragm	Nitrile, Viton or EPDM
4	Diaphragm Plates	304 Stainless Steel
5	Diaphragm Spring*	304 Stainless Steel
6	Cover	486 Brass (DR)

* Spring not used in 25BXX2

SPARE PARTS KITS – BXB SERIES

Kits consist of spring, seal and diaphragm.

MODEL	NITRILE	VITON	EPDM
6BXB2	KM2429A	KM2430	KM2431
10BXB2	KM2429A	KM2430	KM2431
12BXB2	KM1351	KM2433	KM2434
20BXB2*	KM3155C	KM3156C	KM3157C
20BXB3	KM3155	KM3156	KM3157
25BXB2	KM1519	KM2439	KM2440

* Conversion kit from 20BXB2 to 20BXB3

GOYEN 20BAL SERIES

2/2 NORMALLY CLOSED

The 20BAL valves are actuated by a direct solenoid. Valves are designed for high-flow, low-pressure applications. Valves are suitable for use with air or gas.

SPECIFICATIONS

Pressure

Operating pressure range:

0 to 10 kPa (0 to 1.5 psi)

Minimum pressure differential:

0 kPa (0 psi)

Fluid Temperature Range

Nitrile seals:

-40°C to +50°C (-40°F to +122°F)

Ambient Temperatures

0°C to +50°C (32°F to +120°F)

Approved Gases

CSA/UL: Fuel Gas, Natural Gas,

Propane

AGA: Town Gas, Natural Gas, LPG,

TLP, SN

Approvals and Standards

ISO 9001 Quality Management System, Certificate: QEC0366

UL Files: YIOZ.MH9011 YIOZ2.MH9011

CSA File: 26709

AGA Certificate: 5080 AS4629 Class 1

C-Tick Mark, Supplier Code: N282

CE Compliance to Directives

2006/95/EC and 2004/108/EC

RoHS Compliance to Directive

2002/95/EC

Part Number Code:

2 0 B A L - E D A N A - 6 2 8 1

Valve Size

20 3/4" pipe thread

Valve Series

BAL High-flow, low-pressure Gas Valve

Internal Construction

C For use with DC coils only

E For use with AC coils only

Special Features

3 Class 3 Australian Gas Approval

F CSA/UL Recognized Component

D CSA/UL Listed - Safety Valve

Body Material

A Aluminium

N Additional electroless nickel plating

Seal Material

N Nitrile

Port Thread

T RC Thread (BSPT)

A NPT Thread

Coil Options
See page 32.



BAL BD



BAL BR

OPERATING PRESSURE RANGE

VALVE MODEL	PRESSURE	
	KPA	PSI
20BAL	0 to 10	0 to 1.5

CONNECTION AND FLOW

VALVE MODEL	PIPE SIZE		ORIFICE SIZE		FLOW FACTOR	
	MM	INCH	MM	INCH	CV	KV
20BAL	20	3/4	19.0	0.75	7.7	6.62

DIMENSIONS

VALVE MODEL	L		W		H		C		D	
	MM	INCH	MM	INCH	MM	INCH	MM	INCH	MM	INCH
20BAL	82.0	3.23	62.0	2.44	99.0	3.90	41.0	1.61	16.7	0.66

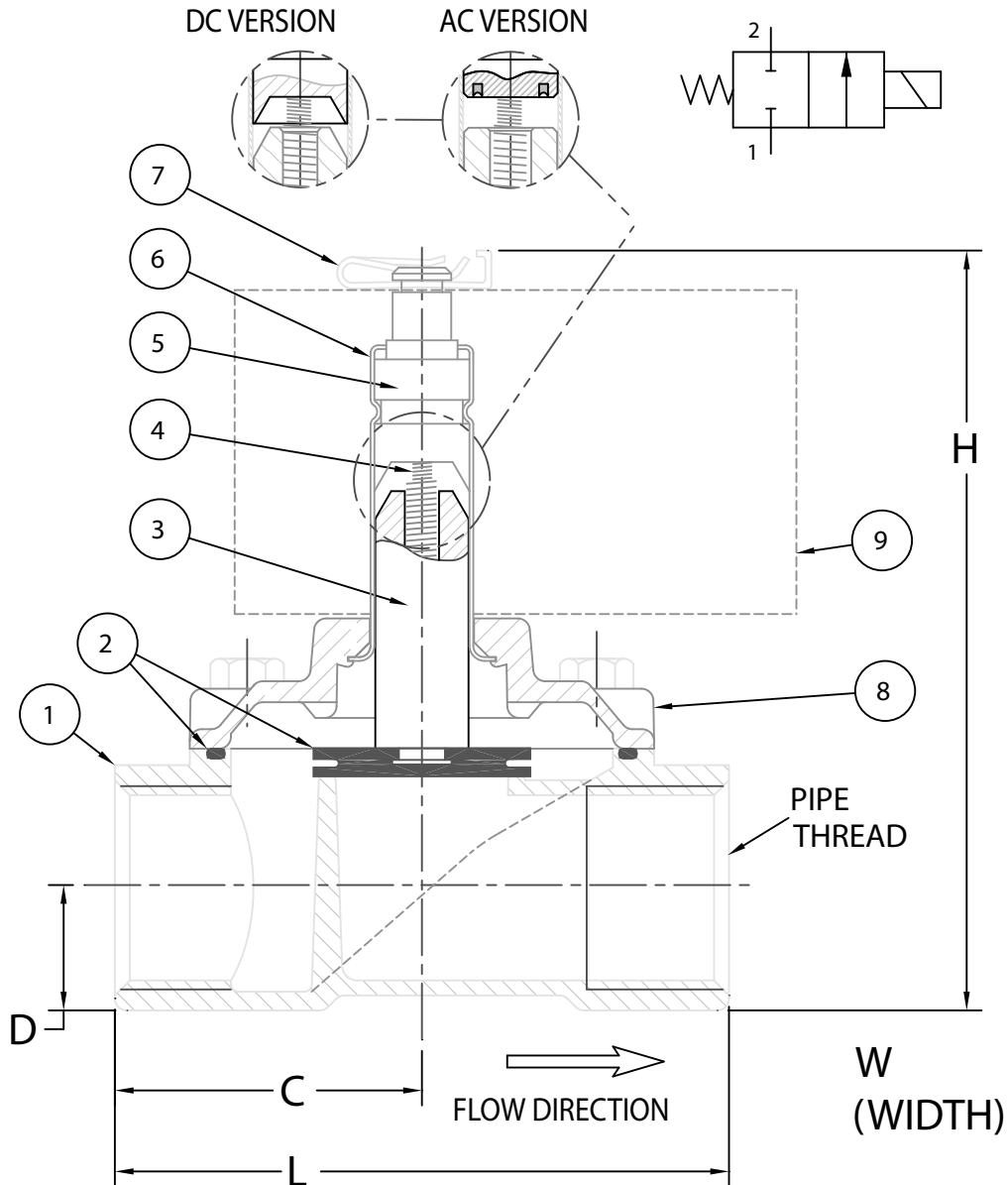

CONSTRUCTION

ITEM	DESCRIPTION	MATERIAL
1	Body	Aluminium CA313
2	Seals	Nitrile Rubber
3	Plunger	430FR Stainless Steel
4	Plunger Spring	304 Stainless Steel
5	Iron Top	430FR Stainless Steel
6	Ferrule Tube	305-4F Stainless Steel
7	Coil Clip	Plated Steel
8	Cover	Aluminium CA313
9	Coils	Refer to page 32.

SPARE PARTS KITS

Kits consist of plunger, spring and seals

MODEL		KIT (NITRILE SEALS)
20BAL	AC	KM3109
	DC	KM2512

GOYEN QLS AND QG SERIES

2/2 NORMALLY CLOSED

Goyen manufactures a range of valves approved for use with gas. These are low pressure, high-flow, direct-lift solenoid valves. Principally used as safety shut-off valves in domestic and commercial gas appliances. Also used in Industrial gas applications with nitrogen, argon and carbon dioxide.

Approvals and Standards

ISO 9001 Quality Management System,
Certificate: QEC0366
CE Compliance to Directives 2006/95/EC and 2004/108/EC
RoHS Compliance to Directive 2002/95/EC

C-Tick Mark, Supplier Code: N282
AGA certification to AS4629
UL certification to UL429

10QLS MODELS 0 TO 7 KPA (0 TO 1 PSI)

VALVE MODEL	CERTIFICATE	CLASS	PORT THREAD	COIL (TYPE Q)**
10QLS-A1ANP	AGA 4283	1	RP 3/8"	AC and DC coils
10QLS-A1ANT			RC 3/8"	
10QLS-C3ANP	AGA 3818	3	RP 3/8"	DC coils only
10QLS-C3ANT			RC 3/8"	
10QLS-E3ANP	AGA 3818	3	RP 3/8"	AC coils only
10QLS-E3ANT			RC 3/8"	

AGA listed fluids: Town Gas, Natural Gas, LPG, TLP & SNG
Temperature Range: -40°C to +60°C (-40°F to +140°F)

'Q' COIL CONNECTION OPTIONS

CONNECTION STYLE	COIL TYPE	CONNECTION CODE	DESCRIPTION
Open C-frame	QT2	83**	Open C-frame, screw terminals
	QF	84**	Open C-frame, flying leads
	Q2	85**	Open C-frame, spade terminals
	QL	86**	Open C-frame, 2-core cable

** Refer to page 32 for voltage options and ratings.

10QLS2 MODELS 0 TO 7 KPA (0 TO 1 PSI)

VALVE MODEL	CERTIFICATE	CLASS	PORT THREAD	COIL (TYPE QE)	COIL CODE
10QLS2-A1ANP	AGA 4978	1	RP 3/8"	240V 50 Hz 3W	8E43
10QLS2-A1ANT			RC 3/8"		

AGA listed fluids: Town Gas, Natural Gas, LPG, TLP & SNG
Temperature Range: -20°C to +80°C (-4°F to +176°F)

10QLS AUTOMOTIVE MODEL 0 TO 7 KPA (0 TO 1 PSI)

VALVE MODEL	CERTIFICATE	CLASS	PORT THREAD	COIL (TYPE QT2)
10QLS-3-T/2433	UL MH9011	Listed (Automotive)	NPT 3/8"	9V DC 9W

UL listed fluids: Propane
Temperature Range: -40°C to +52°C (-40°F to +125°F)

10QG MODEL 0 TO 20 KPA (0 TP 3 PSI)

VALVE MODEL	CERTIFICATE	CLASS	PORT THREAD	COIL (TYPE QD)	COIL CODE
10QG-EDANA	UL MH9011	Listed (Safety)	NPT 3/8"	24 V 60 Hz	7225
				110/120 V 50/60 Hz	7281
				220/240 V 50/60 Hz	7251

UL listed fluids: Natural Gas, LP Gas.
Temperature Range: -34°C to +82°C (-29°F to +180°F)



10QLS



10QLS2



10QLS Automotive



10QG

FLOW

VALVE MODEL	ORIFICE SIZE		FLOW FACTOR	
	MM	INCH	CV	KV
All Models	9.5	0.375	0.1	0.09

DIMENSIONS

VALVE MODEL	L		W		H		C		D		E	
	MM	INCH	MM	INCH	MM	INCH	MM	INCH	MM	INCH	MM	INCH
10QLS	50.8	2.00	41.3	1.63	82.5	3.25	25.4	1.00	12.3	0.48	32.5	1.28
10QLS2	50.8	2.00	41.3	1.63	83.7	3.30	25.4	1.00	12.3	0.48	61.2	2.41
10QG	50.8	2.00	41.3	1.63	83.0	3.27	25.4	1.00	12.3	0.48	62.5	2.46

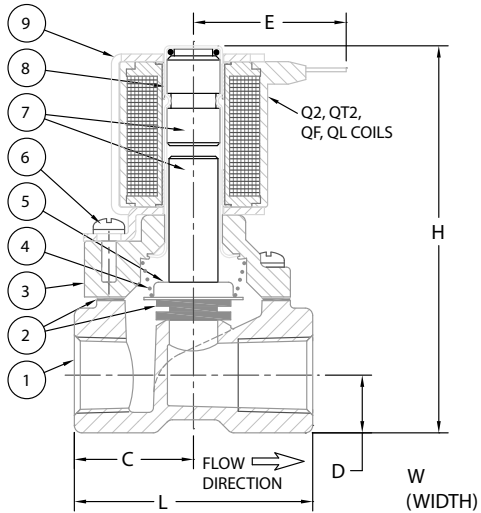

10QLS CLASS 1 CONSTRUCTION

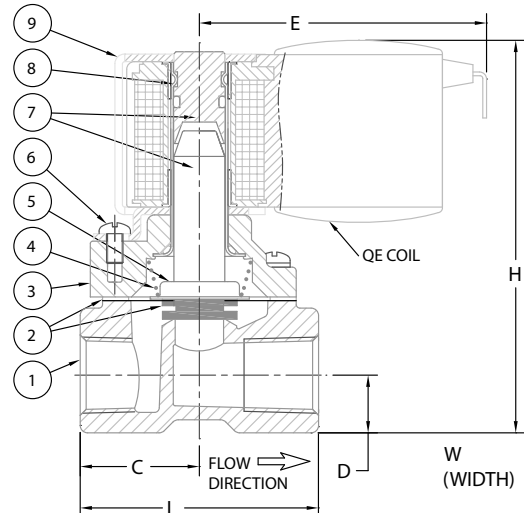

10QLS2 CONSTRUCTION

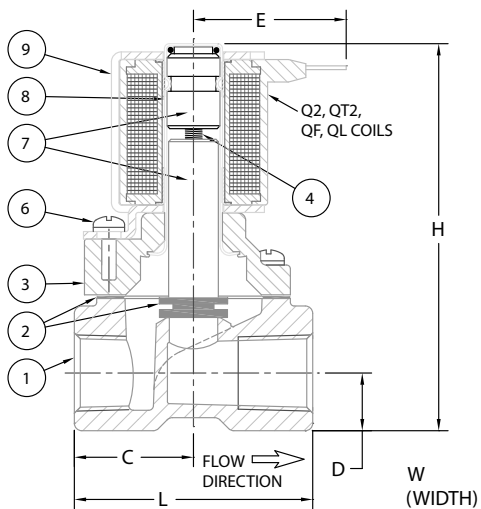

10QLS CLASS 3 CONSTRUCTION

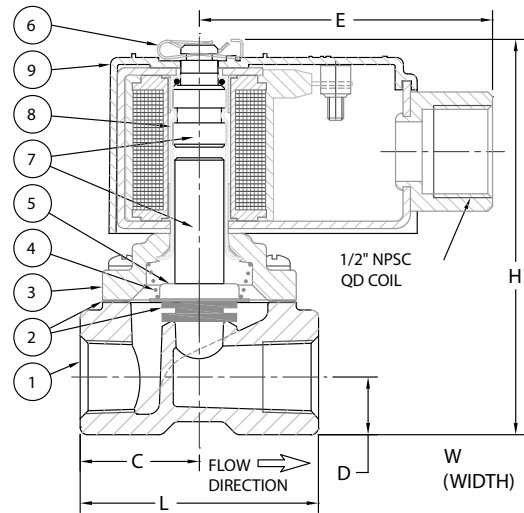

10QG CONSTRUCTION

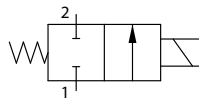

CONSTRUCTION

ITEM	DESCRIPTION	MATERIAL
1	Body	Aluminium CA313
2	Seals	Nitrile Rubber
3	Cover	Aluminium CA313
4	Plunger Spring	304 Stainless Steel
5	Plunger Skirt	304 Stainless Steel
6	Screws, Coil Clip	Plated steel
7	Plunger, Iron-top	430FR Stainless Steel
8	Ferrule Tube	305-4F Stainless Steel
9	Coil Assembly	Refer to page 32.

SPARE PARTS KITS

Kits consist of plunger, spring and gasket

MODEL	KIT NUMBER
10QLS Class 1	KM3088
10QLS Class 3	KM2654
10QLS2	KM2374
10QLS Automotive	-
10QG	KM1975

GOYEN AD4 AND ST2 SERIES

2/2 NORMALLY CLOSED

Goyen manufactures two basic series of moulded plastic solenoid valves. The ST2 series is a high-pressure, pilot-operated diaphragm valve, typically used on dish- and glass-washing machines, agricultural spraying equipment and vending machines. The AD4 series is a low-pressure, direct-lift valve, typically used on dispensing and vending equipment. The valve has a sealed diaphragm to isolate the upper section of the valve from the fluid being controlled.

SPECIFICATIONS

Pressure

Operating pressure range:

Refer to Table.

Minimum pressure differential:

AD4 = 0 kPa (0 psi), ST2 = 20 kPa (3 psi)

Fluid Temperatures

Nitrile and Viton seals:

Fluid temperature range
-34°C to +82°C (-29°F to +180°F)

EPDM seals:

Fluid temperature range
0°C to +95°C (+32°F to +203°F)

Silicone seals:

Fluid temperature range
-34°C to +95°C (-29°F to +203°F)

Ambient Temperatures

-34°C to +40°C (-29°F to +104°F)

Duty Cycle

AD4 valves have 100% duty cycle (continuous operation)

ST2 valves have 50% duty cycle (max. 30 minute on-time)

Approvals and Standards

ISO 9001 Quality Management System, Certificate: QEC0366

C-Tick Mark, Supplier Code: N282

UL Listing: File Y10Z.MH9011 (24 V AC only)

CE Compliance to Directives 2006/95/EC and 2004/108/EC
RoHS Compliance to Directive 2002/95/EC

Part Number Code:

A D 4 - 3 R - C N K E - 8 5 2 7

Valve Size

AD4 Direct-lift valve, diaphragm seal
ST2 Pilot-assisted diaphragm valve

Body Type

H 1/2" hose in/out
3 G3/8" in, 1/2" hose out (except 33, 3A)
4 G1/2" in, 1/2" hose out
6 G3/4" in, 1/2" hose out

Body Type - additional options

Blank In-line ports
R Right-angle ports
3 R3/8" in/out, in-line ports (33 only)
A NPT 3/8" in/out, in-line ports (3A only)

Internal Construction

A For use with either AC or DC coils (ST2 only)
C For use with DC coils only (AD4 only)
E For use with AC coils only (AD4 only)

Special Features

N No special features
E UL Recognised Component (ST2-3A only)

Body Material

K Nylon 66

Seal Material

N Nitrile (ST2 only)
V Viton (ST2 only)
E EPDM (AD4 only)
S Silicone (AD4 only)

Frequency/Rating

2 50 Hz (50% duty ST2)
5 50 Hz (100% duty AD4)
7 DC (100% duty AD4)
8 DC (50% duty ST2)

Voltage Options

See Page 32 (Q coils).

Coil Terminals

5 1/4" Spade Terminals

Coil Assembly

2 For ST2 valves
8 For AD4 valves

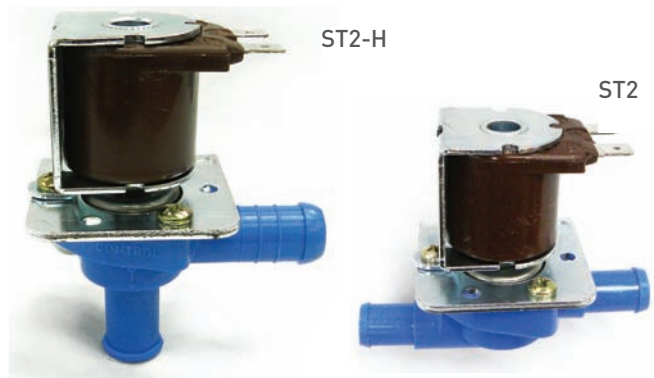

FLOW DATA

VALVE MODEL	ORIFICE SIZE		FLOW FACTOR	
	MM	INCH	CV	KV
AD4	9.5	3/8	1.9	1.63
ST2	9.5	3/8	1.9	1.63

OPERATING PRESSURE RANGE

VALVE MODEL	PRESSURE	
	KPA	PSI
AD4	0 to 7	0 to 1
ST2	20 to 1000	3 to 150

DIMENSIONS AD4 ST2

BODY TYPE	STYLE	INLET	OUTLET	L		M		H	
				MM	INCH	MM	INCH	MM	INCH
H	in-line	1/2" hose	1/2" hose	84.2	3.31	42.9	1.69	72.4	2.85
3	in-line	G 3/8"	1/2" hose	80.7	3.18	39.4	1.55	72.4	2.85
33	in-line	R 3/8"	R 3/8"	87.4	3.44	39.4	1.55	72.4	2.85
3A	in-line	NPT 3/8"	NPT 3/8"	87.4	3.44	39.4	1.55	72.4	2.85
4	in-line	G 1/2"	1/2" hose	84.2	3.31	42.9	1.69	72.4	2.85
6	in-line	G 3/4"	1/2" hose	84.2	3.31	42.9	1.69	72.4	2.85
HR	right-angle	1/2" hose	1/2" hose	70.0	2.76	48.4	1.91	87.0	3.43
3R	right-angle	G 3/8"	1/2" hose	70.0	2.76	39.7	1.56	87.0	3.43
4R	right-angle	G 1/2"	1/2" hose	70.0	2.76	49.2	1.94	87.0	3.43
6R	right-angle	G 3/4"	1/2" hose	70.0	2.76	50.8	2.00	87.0	3.43

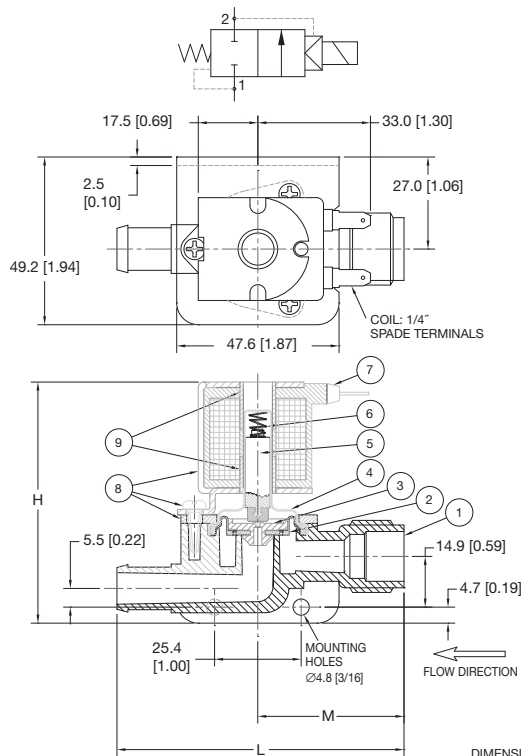

TYPICAL CONSTRUCTION
ST2 VALVE
IN-LINE BODY

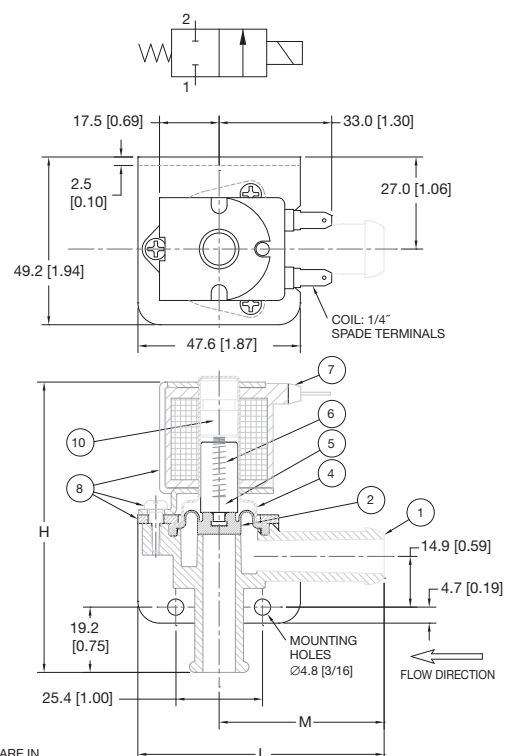

TYPICAL CONSTRUCTION
AD4 VALVE
RIGHT-ANGLE BODY

DIMENSIONS ARE IN
MILLIMETRES (INCHES).

SPARE PARTS KITS

Kit contains plunger, spring and diaphragm.

MODEL		NITRILE	VITON
ST2	AC/DC	KM1673	KM1682

Kit contains ferrule assembly, plunger, spring and diaphragm.

MODEL		EPDM	SILICONE
AD4	AC	KM2134	KM3121
	DC	KM2135	KM3122

CONSTRUCTION

ITEM	DESCRIPTION	MATERIAL
1	Body	Nylon 66
2	Diaphragm	Refer to Part Number Code
3	Diaphragm Insert	Nylon 66
4	Ferrule Tube	305-4F Stainless Steel
5	Plunger	430FR Stainless Steel
6	Spring	304 Stainless Steel
7	Coils	Refer to page 32.
8	Screws and Plates	Plated Steel
9	External Iron-top (ST2)	Plated Steel
10	Internal Iron-top (AD4)	430FR Stainless Steel

GOYEN COILS

FOR USE WITH GOYEN INDUSTRIAL VALVES

DESCRIPTION

Two sizes of coils are used with Goyen industrial valves: 'B' and 'Q'.

Coil size corresponds to the valve part number.

Examples:

12BW2 valves use B series coils.

1Q3M valves use Q series coils.

Ensure the coil electrical rating matches the valve design. Refer to the valve part number code to determine if the valve is designed for AC only or DC only.

All coils are rated for continuous use within the rated ambient temperature range.

Coils may be used in higher ambient temperatures with intermittent operation.

Exd housing (ANZEx) for explosive atmospheres available for B series valves. Refer to separate data page.

SPECIFICATIONS

Maximum ambient temperature:
40°C (104°F)

Duty Cycle: 100% (continuous use)

Maximum coil temperature rise:
90°C (194°F)

APPROVALS AND STANDARDS

ISO 9001 Quality Management System, Certificate: QEC0366

C-Tick Mark, Supplier Code: N282
CE Compliance to Directives 2006/95/EC and 2004/108/EC
RoHS Compliance to Directive 2002/95/EC

MATERIALS

B coil bobbin & encapsulation:
Polyamide 6 (glass filled)

Q coil bobbin & encapsulation:
Polyamide 66 (unfilled)

Winding wire: Copper, Polyester imide enamel

Terminals: Tin-plated brass

Lead wires: 18 AWG, Rated 105°C (UL type 1015)

Inserts, C-frames, Clips: Plated steel

B COILS – ELECTRICAL CHARACTERISTICS

COIL CODE*	VOLTS	HZ	INRUSH MA	HOLDING MA	WATTS
6*33	415	50	80	30	7
6*43	240	50	172	70	9
6*51	220/240	50/60	182/162	71/62	8
6*81	110/120	50/60	405/370	157/142	9
6*B5	48	60	1070	410	10
6*B3	48	50	980	380	8
6*C3	32	50	1260	520	8
6*21	24	50/60	2000/1720	830/660	10
6*D3	12	50	4040	1640	10
6*47	240	DC	–	48	12
6*97	110	DC	–	113	13
6*G7	74	DC	–	148	11
6*B7	48	DC	–	302	15
6*C7	32	DC	–	322	11
6*27	24	DC	–	596	15
6*D7	12	DC	–	1200	15

Q COILS – ELECTRICAL CHARACTERISTICS

COIL CODE*	VOLTS	HZ	INRUSH MA	HOLDING MA	WATTS
7*33	415	50	36	22	5
7*43	240	50	86	55	8
7*51	220/240	50/60	89/83	62/50	8
7*81	110/120	50/60	192/180	123/110	8
7*C1	32	50/60	590/490	370/285	8
7*23	24	50	800	520	8
7*25	24	60	822	510	8
7*D3	12	50	1238	788	8
7*47	240	DC	–	39	10
7*97	110	DC	–	81	9
7*G7	74	DC	–	116	9
7*B7	48	DC	–	188	9
7*C7	32	DC	–	262	9
7*27	24	DC	–	364	9
7*D7	12	DC	–	719	9

* Refer to coil connection code.

* Refer to coil connection code.

COIL CONNECTION CODE

CONNECTION STYLE	COIL TYPE	CONNECTION CODE	DESCRIPTION
DIN Connector IP65/NEMA 4	BR, QR	0	DIN Socket – plain
	BR, QR	G	DIN socket – indicator
	BR, QR	P	DIN socket – indicator and overload protection
Enclosure IP31/NEMA 1	BD, QD	1	M20 conduit, screw terminals
	BF	7	M20 conduit, flying leads
	BD, QD	2	1/2" NPSC conduit, screw terminals
Open C-frame	BF	8	1/2" NPSC conduit, flying leads
	BC, QT2	3	Open C-frame, screw terminals
	BF, QF	4	Open C-frame, flying leads
	Q2	5	Open C-frame, spade terminals
	QL	6	Open C-frame, 2-core cable

GOYEN B SERIES COILS

FOR USE WITH GOYEN INDUSTRIAL VALVES



BD

DIMENSIONS

COIL STYLE	W		H		A		B		ID	
	MM	INCH	MM	INCH	MM	INCH	MM	INCH	MM	INCH
BC	41.5	1.63	39.0	1.54	22.8	0.90	31.7	1.25	14.0	0.55
BD	49.8	1.96	44.5	1.75	24.8	0.98	57.4	2.26	14.0	0.55
BF	41.5	1.63	39.0	1.54	22.8	0.90	23.0	0.91	14.0	0.55
BR	48.8	1.92	45.0	1.77	26.7	1.05	65.2	2.57	14.0	0.55



BC

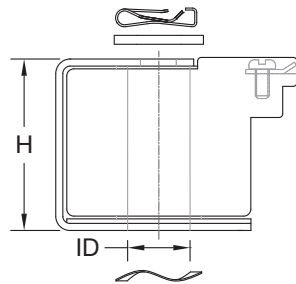
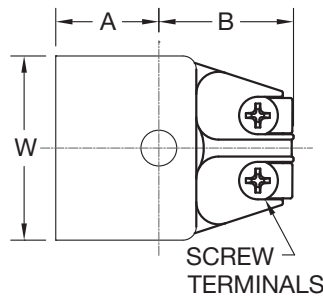

BC COIL

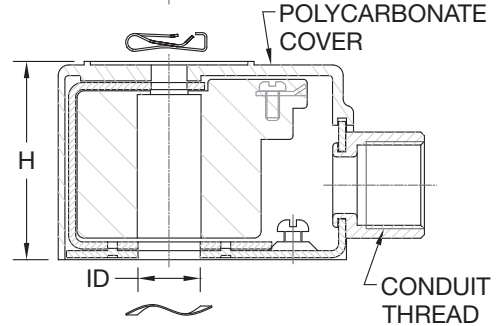
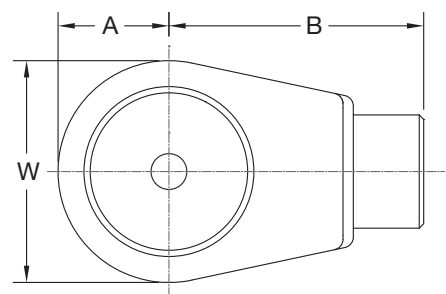

BD COIL



BF

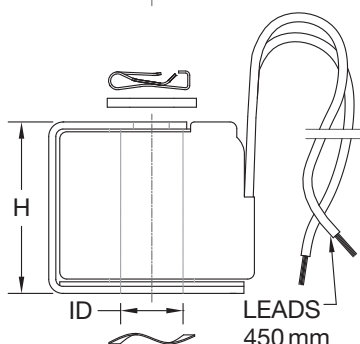
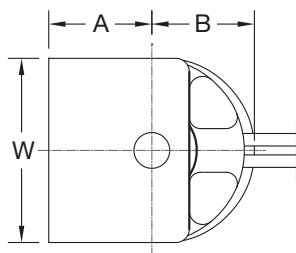

BF COIL
LEADS
450mm
[18"]

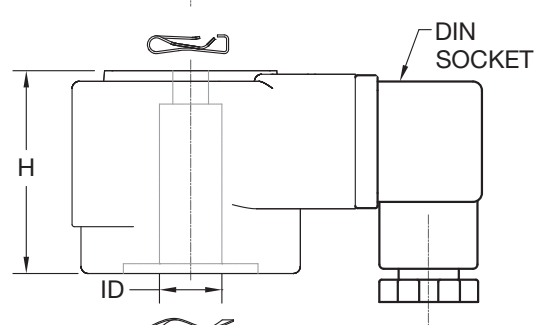
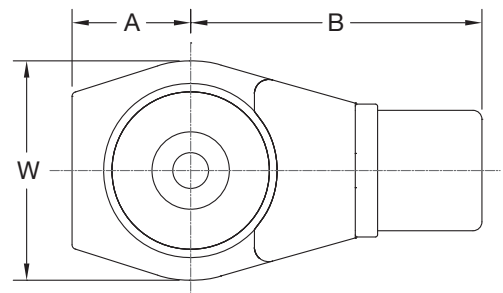

BR COIL



BR

GOYEN Q SERIES COILS

FOR USE WITH GOYEN INDUSTRIAL VALVES



QD

DIMENSIONS

COIL STYLE	W		H		A		B		ID	
	MM	INCH	MM	INCH	MM	INCH	MM	INCH	MM	INCH
Q2	31.4	1.24	34.5	1.36	17.5	0.69	32.5	1.28	12.3	0.48
QD	38.7	1.52	38.3	1.51	19.1	0.75	62.5	2.46	12.3	0.48
QF	32.8	1.29	34.5	1.36	17.5	0.69	18.2	0.72	12.3	0.48
QR	37.4	1.47	40.4	1.59	18.8	0.74	52.2	2.06	12.3	0.48
QT2	31.6	1.24	34.5	1.36	17.5	0.69	32.5	1.28	12.3	0.48



Q2



QT2



QF



QR

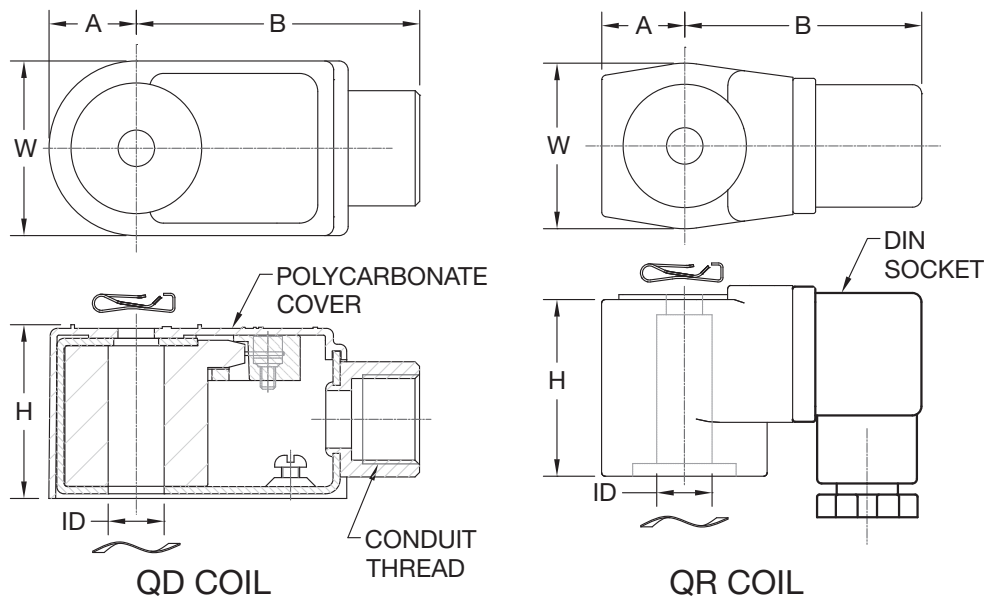
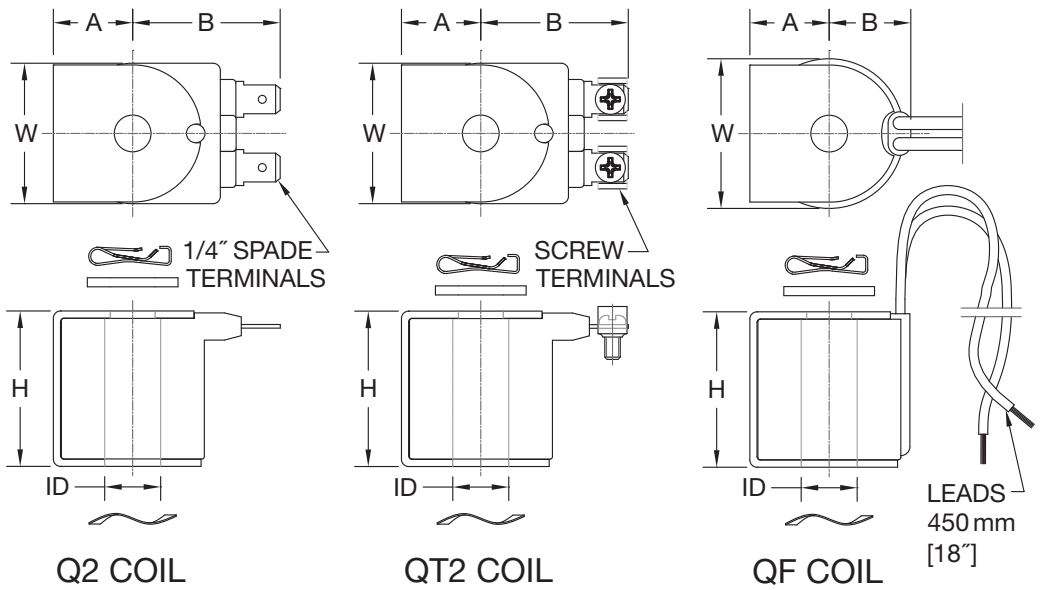

GOYEN BH SERIES COILS

FOR USE WITH GOYEN INDUSTRIAL VALVES

DESCRIPTION

The Goyen BH series is an explosion proof housing for use in hazardous gas and dust environments.

SPECIFICATIONS

Ambient temperature:
-20°C to +40°C (-4°F to +104°F)

Duty Cycle: 100% (continuous use)

Maximum coil temperature rise:
90°C (194°F)

BH HOUSING MATERIALS

Housing Cover: Aluminium Alloy 2011
(Enamel painted exterior)

Housing Base, Inserts and C-frame:
Plated steel

Housing Seal: Nitrile rubber

Lead wires: 18 AWG, Rated 105°C (UL type 1015)

APPROVALS AND STANDARDS

Certificate: ANZEx 07.3026X

Enclosure Cat. No. 604320

Ex d IIB T* IP65

DIP T* IP65

(*AC coils T3, DC coils T5)

UL Listing: File E53107

Class I, Groups C and D

Class II, Groups E, F and G

ISO 9001 Quality Management System,

Certificate: QEC0366

C-Tick Mark, Supplier Code: N282

CE Compliance to Directives

2006/95/EC and 2004/108/EC

RoHS Compliance to Directive

2002/95/EC

Part Number Code:

4 B 6 M - L H B N T - 6 B 2 1

Valve series

B6M series
B6M3 series
12, 20 BWJ series
12, 20, 25, 40 BW series

Valve option – standard valve options

G Normally closed, AC or DC coils
H Normally open, AC or DC coils
J Normally closed, DC coils only
L Normally closed, AC coils only

Approval type

H ANZEx Certification
U UL Certification

Other valve features

Refer to standard valve options

Coil series

6 Goyen 'B' series coils

Housing type

B M20 conduit thread – ANZEx certification
C 1/2" NPSC conduit thread – UL Certification

Voltage options – Refer to electrical details for 'B' series coils

33	415 V 50 Hz	
43	240 V 50 Hz	* UL certification
51*	220/240 V 50/60 Hz	for these voltages only
81*	110/120 V 50/60 Hz	
C3	32 V 50 Hz	
21*	24 V 50/60 Hz	All voltage options available
97	110 V DC	with ANZEx certification
27	24 V DC	
D7	12 V DC	





CLEANAIRSYSTEMS.COM

© 2014 Pentair Clean Air Systems reserves the right to change product designs and specifications without notice.